

© KIET IJCE

**KIET International Journal of
Communications & Electronics**

VOLUME 5, FIRST ISSUE, JAN-JUNE 2017,
ISSN:2320-8996



Editorial Board

Editor in Chief

Dr. Sanjay Sharma

Professor & Head, ECE Department
KIET Group of Institutions
(NAAC 'A' Grade, NBA Accredited and ISO 9001-2000)
13-Km Stone, Ghaziabad-Meerut Road,
Ghaziabad-201206, UP, INDIA
Email ID: - drsanjaysharma15@gmail.com

Editors

Dr. Vibhav Kumar Sachan,

Additional HoD, ECE Dept., KIET Group of Institutions, Ghaziabad, U.P.

Dr. Dharmendra Kumar

ECE Dept., KIET Group of Institutions, Ghaziabad, U.P.

Prof. Sarika Pal

ECE Dept., KIET Group of Institutions, Ghaziabad, U.P.

Prof. Shipra Srivastava

ECE Dept., KIET Group of Institutions, Ghaziabad, U.P.

Prof. Pooja Tyagi

ECE Dept., KIET Group of Institutions, Ghaziabad, U.P.

Prof. Ila Aggarwal

ECE Dept., KIET Group of Institutions, Ghaziabad, U.P.

Sub Editors

Prof. (Dr.) Vipin Kumar

AS & H Dept., KIET Group of Institutions, Ghaziabad, U.P.

Prof. (Dr.) Sumita Ray Choudhary

HoD, EIE, KIET Group of Institutions, Ghaziabad, U.P.

Patrons

Shri M.P. Jain

Chairman, KIET Group of Institutions, Ghaziabad, U.P.

Dr. Anil Ahlawat

Director, KIET Group of Institutions, Ghaziabad, U.P.

Editorial

Do you think about the wireless future of our planet? The rate at which technology is expanding isn't a surprise. The world today can easily be termed as the "GADGET WORLD", given the astonishingly high rates at which gadgets are being developed, manufactured, and ultimately exploited by the end users. This issue will give an idea consisting of some of the new technology supporting wireless world. The technologies like Sixth sense, IOT, LiFi, GiFi, NFC, wireless power transmission, EnOcean tech etc has been developed in the recent years. If these technologies would be supported the time is very soon where you would see the world without cables and power cords.

Cloud computing is an information technology (IT) paradigm that enables ubiquitous access to shared pools of configurable system resources and higher-level services that can be rapidly provisioned with minimal management effort, often over the Internet. Cloud computing relies on sharing of resources to achieve coherence and economies of scale, similar to a public utility. Cloud Computing supports Hadoop framework to process BigData in parallel. Hadoop has certain limitations that could be exploited to execute the job efficiently. H2Hadoop is an enhanced Hadoop architecture that reduces the computation cost associated with BigData analysis. It addresses the issue of resource allocation in native Hadoop, also it provides an efficient data Mining approach for Cloud Computing environments.

The onset of the Information Age is associated with the Digital Revolution. Digital games are non-linear, interactive, and participatory entertaining activities played on consoles, computers, mobile phones and other digital devices. A game is combination of game art and game logic. There are some integral elements of a game such as graphics and animation, interactivity, user interface, game play, sound etc. Elements of games for mobile games are different. An investigation which element of game is important to what extent for common gamers, a study done on a group of students of a class studying Animation and Multimedia and Digital Games. This will help game designers to understand the mindset of Indian gamers and help in developing more successful games.

Researcher have done lots of investigation in the area of robotics and wireless sensor network (WSN) independently, but if integrate this two areas then it would support to lots of application such as underwater, disaster management, nuclear power station, space exploration, military, healthcare etc. We can use robot to solve number of problems of wireless sensor network just like a localizing of nodes, and also robot can be used as a data mules for aggregating data from different sensor nodes. We can also build a wireless sensor network using autonomous mobile robots instead of sensor node; the use of mobile robots gives accurate positioning. Received signal strength is used to get accurate position of mobile robots. Along with power requirement of WSN this approach makes a sense.

Preface

Dear Researchers,

We take this opportunity to welcome you all to the Volume No 5, Issue No. 1 of International Journal of Communications & Electronics (KIET - IJCE). This journal will provide a forum for in depth and substantial discussions on the theory, design and implementation of the emerging technologies in Communications, Networking, Microwave and Electronics techniques, thus providing solutions and strategies for business resilience.

It gives us an immense pleasure to have an amalgam of researchers from the fields of Communication Engineering, Electronics, and related technologies. The purpose of the Journal is to provide a platform to foster interdisciplinary communication among the delegates and to support the sharing process of diverse fields in various concepts and principles related to these domains.

Our appreciation also goes to entire team whose dedication and timeless efforts have gone for number of days for the second issue of the Journal.

Editors



Message

I am delighted to note that the Department of Electronics and Communication Engineering, KIET Group of Institutions, Ghaziabad is introducing Volume No 5, Issue No. 1 of International Journal of Communications and Electronics (KIET - IJCE).

I appreciate the efforts on the part of the Editorial Committee in bringing out an issue on Communications, Networking, Microwave and Electronics techniques.

I understand that the papers contributed for publication in the Volume No 5, Issue No. 1 are on almost all the current aspects of Communication Systems, Electronics systems, Microwave Engineering, Signal Processing & Applications, Networking Technologies and several others.

I have great pleasure in congratulating the Editors of this issue of KIET - IJCE for their untiring efforts in bringing out this third Volume No 5, Issue No. 1 of KIET-IJCE which will be a valued treasure for all who pursue research in Communications, Networking, Microwave and Electronics Engineering areas.

Let me close with warmest regards.

Dr. Anil Ahlawat
Director
KIET



Message

It gives me immense pleasure in writing this foreword for the Volume No 5, Issue No.1 of the KIET International Journal on Communications and Electronics (KIET - IJCE). This journal is targeted towards researchers, professionals, educators and students to share innovative ideas, issues, recent trends and future directions in the fields of Electronics and Communication Engineering.

The Volume No 5, Issue No. 1 of the journal KIET-IJCE includes papers on the theory, design and implementation of the emerging technologies in the field of Communications, Networking, Microwave and Electronics techniques. Furthermore, it will enable the researchers in various domains to foster the exchange of concept, prototypes, research ideas and the results of research work which could contribute to the academic arena and also benefit business and industrial community.

Dr. Sanjay Sharma
Editor – in - chief
KIET - IJCE

S-Hadoop -An enhancement of H2Hadoop

Shruti Satpute¹, Shalaka Zaware², Ganesh Phapale³, Shubham Shahane⁴

^{1,2,3,4}Department of Computer Engineering,

Amrutvahini College of Engineering, Sangamner, Ahmednagar, Maharashtra, India

Savitribai Phule Pune University, Maharashtra, India

¹shrutisatpute7@gmail.com

²shalakazaware@gmail.com

³ganeshphapale77@gmail.com

⁴32shubham32@gmail.com

Abstract-Cloud Computing supports Hadoop framework to process BigData in parallel. Hadoop has certain limitations that could be exploited to execute the job efficiently. These limitations are mostly because of data locality in the cluster, jobs and tasks scheduling, and resource allocations in Hadoop. Maintaining efficiency in resource allocation still remains a challenge in Cloud Computing. MapReduce platforms. H2Hadoop is an enhanced Hadoop architecture that reduces the computation cost associated with BigData analysis. It addresses the issue of resource allocation in native Hadoop, also it provides an efficient. Data Mining approach for Cloud Computing environments. H2Hadoop architecture leverages on NameNodes ability to assign jobs to the TaskTrackers (DataNodes) within the cluster. By adding control features to the NameNode, H2Hadoop can intelligently direct and assign tasks to the DataNodes that contain the required data without sending the job to the whole cluster but the single node gets overloaded due to this. A S-Hadoop system is proposed which makes use of concepts like data deduplication and indexing. S-Hadoop uses efficient searching algorithms which will solve this problem. An efficient searching technique for retrieval of data is been proposed.

Keywords— Cloud Computing, BigData, Hadoop, H2Hadoop, S-Hadoop, Fault tolerance, HDFS, Name node, Data node, MapReduce, Text Data, Data Deduplication, Indexing.

I. INTRODUCTION

This Hadoop is an Apache project, Java based open source framework which distributes processes of huge database sets through clusters of computers using models of programming. A Hadoop works in an background frame work that provides distributed storage and computing system across computers cluster. Hadoop is designed to increase scalability from one server to multiple of machines.[1]

H2Hadoop is an enhanced Hadoop architecture that reduces the computation cost associated with BigData analysis. It addresses the issue of resource allocation in native Hadoop, also it provides an efficient Data Mining approach for Cloud Computing environments. H2Hadoop architecture leverages on NameNodes

ability to assign jobs to the TaskTrackers (DataNodes) within the cluster. By adding control features to the

NameNode, H2Hadoop can intelligently direct and assign tasks to the DataNodes that contain the required data without sending the job to the whole cluster but the single node gets overloaded due to this. In this project an enhanced version of H2Hadoop is proposed. Which is S-Hadoop system. A S-Hadoop system is proposed which makes use of concepts like data deduplication and indexing. S-Hadoop uses efficient searching algorithms which will solve this problem. An efficient searching technique for retrieval of data is been proposed.

Use of Indexing and Deduplication is done to perform further operations on BigData.

II. EXISTING SYSTEM

A. Hadoop Overview

Hadoop is HDFS. In which a MapReduce process that application is divided into many small pieces of task each of which may be executed on the nodes of Hadoop Clusters. MapReduce provides flow reading access, runs tasks on a cluster of nodes, and provides a data controlling system for a expanded data storage system. Application for transferring data to the databases Mysql and Hadoop. It can make compatible with incremental loads of a single table or a free form SQL query MapReduce algorithm has used for applications like creating search indexes, document clustering, access logs, and different data analysis. "one time write and multiple times read" this can be permites to data files to be written only once in HDFS and then permites to be multiple times reading with respect to the numbers of distributed jobs. During the writing process, Hadoop distributes the information into predefine blocks with size.[1]

B. Common Job Block Table

The H2Hadoop MapReduce workflow is the same as the original Hadoop in terms of hardware, network, and nodes. However, the software level has been enhanced. We only add features in NameNode that allow it to save specific data in a look up table which is called as Common Job Blocks Table CJBT.



C. The Common Feature

Common Features are define as the shared data between jobs. H2Hadoop supports caching, enables output to be written in the CJBT during the reduce step. We use Common Features to identify the DataNodes or the blocks with shared data entries.

III. PROPOSED SYSTEM

In the given paper, system of data searching and avoiding the complexity we implement the concept of the paper in which by using the MySQL, BigDataHadoop and using Java Language project implemented. In the proposed system firstly run Hadoop on the windows 7 operating system by using virtual machine(VMware). After the Hadoop execution creating the cluster and node to HDFS. Then Mapreducing can be done for sorting the input. In this project building a cluster for the proposed solution following some directions to prepare the cluster first, then we can do the modifications on the environment. In addition, since in this have Hadoop and MySQL both run on a shell interface of windows, in this will use it for the implementation of the proposed solution.

A. MapReduce

MapReduce is a framework which is used for easily distribution, fault-tolerant manner. A MapReduce job usually splits the input set into independent chunks which are processed by the map tasks in a completely parallel manner. The framework sorts the outputs of the maps, which are then input to the reduce tasks. The execute nodes and the storage nodes are the same, MapReduce and the HDFS are running on the same set of nodes The MapReduce framework consists of a one master and single slave TaskTracker for each cluster-node.[12]

B. S-Hadoop

No Parallel processing in Cloud Computing has emerged as an interdisciplinary research area due to the heterogeneous nature and large size of data. Sequential pattern mining or data analysis applications such as reduce the amounts of data processing and computational capabilities.[9] Efficiently targeting and scheduling of computational resources is required to solve such complex problems. In Hadoop architecture location of the blocks in HDFS is knowing by NameNode. NameNode is allocate the tasks to a client and divides that job into tasks. It knows which DataNode holds the blocks containing the optional data. NameNode able to direct the jobs to the specific DataNodes without going through the whole cluster. In H2Hadoop, first we add a pre-processing phase in the NameNode and then assigns the tasks. In which focus is on identifying and extracting features to build a metadata table that store information of the location of the data blocks with job name and features.

1) Flowchart:

Flowchart explained in Figure 1, we can see that there are two more conditions i.e Indexing and Datededuplication in S-Hadoop. when compared with H2Hadoop that perform with a delay in job processing. However, if we have a relationship between jobs,S-Hadoop performance will be better than the H2 Hadoop.[11]

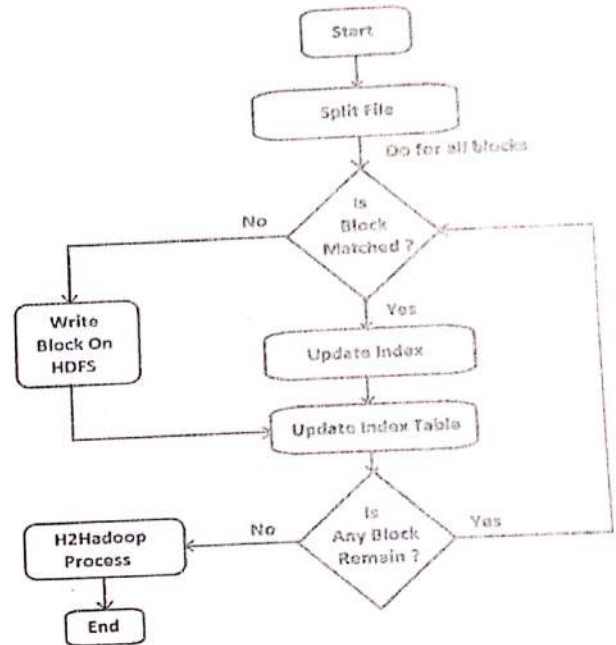

Fig. 1 S-HadoopFlowdigram

2) Algorithms:

Indexing Algorithm:

Step 1: Take multiple databases(two or more)
 Step 2: Sort the database using BKV's(blocking key value). Fix the window size w and it should be always greater than 1 i.e.(w>1) This window is moved over data sequentially to get similar record pairs.
 Step 3: Linking of records is done.

For record linkage consider following terms,
 (nA + nB): total no of records in both the databases
 (nA + nB - w + 1): total no of window positions.
 Total no of unique candidate pairs generated equals to:

$$uSNDSA = \frac{w(w-1)}{2} + (nA - w)(w-1)$$

$$= (w-1)(nA-w/2)$$

Pseudo Code:

Step 1: Start
 Step 2: Take the multiple databases (two or more)
 Step 3: Sort the databases using BKV's (Blocking key values)



- a. Fix the window size for comparison, ($w > 1$), which will move sequentially over data.
- b. Compare record pairs within current window.

Step 4: BKV's are inserted into array that is sorted alphabetically from left hand side of array

Step 5: Then window is moved over this array and candidate record pair are generated in current window.

Step 6: In case of record linkage, BKV's from both databases will be inserted into combine array and sorted alphabetically, such that for each pair one record is selected from each of two database.

Step 7: End

3) Architecture Workflow:

A S-Hadoop Architecture has been explained in figure 2 as follows:

Step 1: Client "A" sends a request to NameNode. The request includes the need to copy the data files to DataNodes.

Step 2: NameNode replies with the IP address of DataNodes. In the above diagram NameNode replies with the IP address of five nodes (DN1 to DN5).

Step 3: Client "A" accesses the raw data for manipulation in Hadoop.

Step 4: Client "A" formats the raw data into HDFS format and divides blocks based on the data size. Update index after checking DB. In the above example the blocks B1 to B4 are distributed among the DataNodes.

Step 5: Client "A" sends the three copies of each data block to different DataNodes.

Step 6: In this step, client "A" sends a MapReduce job (job1) to the JobTracker daemon with the source data file name(s). Step

Step 7: JobTracker sends the tasks to all TaskTrackers holding the blocks of the data.

Step 8: Each TaskTracker executes a specific task on each block and sends the results back to the JobTracker.

Step 9: JobTracker sends the final result to Client "A". If client "A" has another job that requires the same datasets it repeats the set 6-8.

Step 10: In native Hadoop client "B" with a new MapReduce job (job2) will go through step 1-5 even if the datasets are already available in HDFS. However, if client "B" knows that the data exists in HDFS, it will send job2 directly to JobTracker.

Step 11: JobTracker sends job2 to all TaskTrackers.

Step 12: TaskTrackers execute the tasks and send the results back to the JobTracker.

Step 13: JobTracker sends the final result to Client "B". [1]

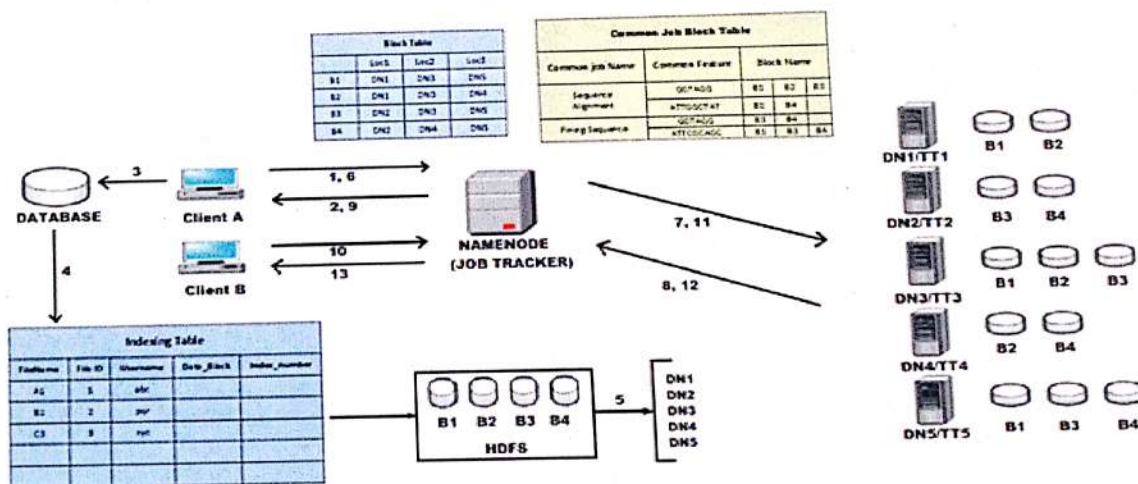

Fig. 2 S-Hadoop Architecture

C. Indexing

In H2Hadoop, by design – massively parallel, scalable, data agnostic, and hardwired to full row or column scans is not suitable for indexing. This essential technology is key to traditional DBMS, keeping the performance high-ground over h2Hadoop on (near) real-time analytical tasks. But using indexing algorithms and data deduplication techniques we present enhanced version of H2hadoop that is S-Hadoop. S-Hadoop Indexing table, addressing the indexing problem at the beginning of the S-Hadoop pipeline when data is uploaded to HDFS. In Indexing table FileName, fileID, User_name, data_block, index_number parameters are used. S-Hadoop, by default, keeps three identical copies of each data block distributed between datanodes in the cluster for redundancy and parallel performance through data locality. The indexing achieved a speed-up of up to 20 times by mainly reducing the data required to be read by mappers. This requires anticipation of the workload for optimal index design, and extra time to create the indices. It also update information parallely.

IV. CONCLUSIONS

In Enhanced H2Hadoop framework (S-Hadoop), which allows a NameNode to identify the blocks in the cluster where certain information is stored. And updating the index. A secure, efficient scheme is proposed, which searches common blocks in Bigdata and allows us to perform operation on it which results in less memory storage, CPU time cost. In turn giving faster access and analysis of data.

ACKNOWLEDGMENT

It gives us great pleasure in presenting the paper on S-HADOOP AN ENHANCED H2HADOOP. We would like to take this opportunity to thank our guide Prof. S. A. Thanekar for giving us all the help and guidance we needed. We are really grateful to him for his kind support. His valuable suggestions were very helpful. And Also thanks to Michael Shell and other contributors for developing

and maintaining the KIETIJCELaTeX style files which have been used in the preparation of this template.

REFERENCES

- [1] HamoudAlshammari, Jeongkyu Lee and Hassan Bajwa, H2Hadoop: Improving Hadoop Performance using the Metadata of Related Jobs, IEEE TRANSACTIONS ON Cloud Computing, manuscript ID TCC-2015-11-0399.
 - [2] HamoudAlshammari, Jeongkyu Lee, Hassan Bajwa: Improving Current Hadoop MapReduce Workflow and Performance", Volume 116 No. 15, April 2015.
 - [3] Abhilasha Singh, Chetali Parve, Priyanka Tripathi 'Analysis of Map Reduce Performance using Prefetching Mechanism", Volume 128 No.11, October 2015.
 - [4] Zeba Khanam and Shafali Agarwal Map-reduce implementation performance comparison", August 2015. A. Ahmad Sharif, B. Akram Noorollahi Intrusion Detection and Prevention Systems (IDPS) and Security Issues", International Journal of Computer Science and Network Security, VOL.14 No.11, November 2014
 - [5] Qi, C., L. Cheng, and X. Zhen, Improving MapReduce Performance Using Smart Speculative Execution Strategy. Computers, IEEE Transactions on, 2014, 63(4): p. 954-967..
 - [6] Farrahi, K. and D. Gatica-Perez, A probabilistic approach to mining mobile phone data sequences. Personal Ubiquitous Comput., 2014, 18(1): p. 223-238.
 - [7] A. Ahmad Sharif, B. Akram Noorollahi Intrusion Detection and Prevention Systems (IDPS) and Security Issues", International Journal of Computer Science and Network Security, VOL.14 No.11, November 2014
 - [8] Rong Gua, Xiaoliang Yanga, Jinshuang Yana, Yuanhao Sunb, Bing Wangb, Chunfeng Yuana, Yihua Huang a 'SHadoop: Improving MapReduce performance by optimizing job execution mechanism in Hadoop clusters", 2013.
 - [9] Ming, M., G. Jing, and C. Jun-jie. ,Blast-Parallel: The parallelizing implementation of sequence alignment algorithms based on Hadoop platform. in Biomedical Engineering and Informatics (BMEI), 2013 6th International Conference on. 2013.
 - [10] Jian Tan, Xiaoqiao Meng, Li Zhang: Coupling Task Progress for MapReduce Resource Aware Scheduling", 2013.
 - [11] Wei Luo, Nicholas Woodward for Analysis and Optimization of Data Import with Hadoop, 2012 IEEE 26th International Parallel and Distributed Processing Symposium Workshops.
- Matsunaga, A., M. Tsugawa, and J. Fortes. CloudBLAST: Combining MapReduce and Virtualization on Distributed Resources for Bioinformatics Applications. in Science, 2008. eScience '08. IEEE Fourth International Conference on. 2008..

STUDY TO FIND PATTERNS OF GOOD MOBILE GAMES

Mehta Niket

Department of Animation and Multimedia,
Birla Institute of Technology, Mesra: Ranchi, Noida,
niket@bitmesra.ac.in

ABSTRACT

Digital games are non-linear, interactive, and participatory and entertainment activities played on consoles, computers, mobile phones and other digital devices. These days, in India and everywhere in world, smart phones have become a very common thing. Everywhere, we happen to see people engaged on smartphones. Smartphones have lots of apps which may serve some utility or entertainment. Games are also available on mobile app stores in free and paid form. There are games which player may purchase after trying or may unlock its further levels by paying. There are games on all mobile app stores for every taste and preferences, be it children or elders, boys or girls, youngsters, women or hard-core gamers. A game is combination of game art and game logic. There are some integral elements of a game such as graphics and animation, interactivity, user interface, game play, sound etc. There are texts available which discuss elements of games in terms of Digital games on console and computer but not on mobile device. This study discusses the elements of games for mobile games. This paper investigates which element of game is important to what extent for common gamers. A study done on a group of students of a class studying Animation and Multimedia and Digital Games in an institute of higher education in Delhi NCR, India reveals which mobile games are liked by them and what elements of a game attract them. This paper can help game designers to understand the mindset of Indian gamers and help in developing more successful games.

INTRODUCTION – DIGITAL GAMES AND ITS ELEMENTS

Digital games are technology-aided learning tools which can be used for entertainment as well. Good games are good learning machines. While making a

digital game, not only the game art and game logic; the two integral components of game design are considered yet lot many elements of a game are planned by game designer after doing thorough research and observation. Games which are looked upon as a form of entertainment and as a tool for learning influence the people and culture and vice versa. So, an understanding of audience, their society and the topic of the game is necessary for game design. Board games and traditional games have always been inspiration for new games. No doubt, ever improving technology for example virtual reality options enhance the interactivity, impressiveness and quality of games or virtual interactive entertainment; which is going to be a big boom in coming times. In such an environment, to develop good games; an understanding of basic building blocks or integral components of a game is important. Various texts have documented the elements of games in diverse ways.

Digital games have come along way since their birth in the late 70's and are one of the most popular forms of entertainment even today. Games have changed platforms from consoles to mobile phones. The elements of a game have been given in Game Theory which is a theory of Mathematics given by John von Neumann and Morgenstern (1944) and Game Designers concepts like Chris Crawford, Andrew Rollings and Ernest Adamshave also given elements of game according to Game Design principles.

According to Game Theory, a game must specify the following elements: the players of the game, the information and actions available to each player at each decision point, and the payoffs for each outcome. [Game Theory, Wikipedia] Game theory is mainly used in economics, political science, and psychology, as well as logic, computer science, and



biology. [econ.uiuc.edu] One should keep in mind that elements of game for Game theory and Game (as per Game Designers) are slightly different.

According to Game Designers Tracy Fullerton and Chris Swain (2014), the formal elements of a game are players, objectives, rules, procedures and resources. Chris Crawford (1982) perceives four common factors of a game - representation, interaction, conflict, and safety.

Traditionally the 'story' always comes first in any game and without an exceptional story we can't have a great game. While this is for the most part true, gameplay is equally important as story and as important for achieving a great game. In some cases, a hit game can be built entirely on great gameplay without much of a story just like in "Angry Birds" which is a mobile hit game. This game doesn't focus on drawing players into the story, but it has incredible gameplay which makes it a success. A game can have an awesome story, but if the gameplay is bad there'd be no reason to play it. [pluralsight.com] Games need to be 'interactive' to make them fully 'immersive'. Games give 'control' to players and add 'interactivity' unlike movie where end-user is a passive observer only not a participant. These 'controls' (choices) should add fun in the games not the complexity. "It doesn't matter if the gameplay is complex or simple, it needs to be solid. It should feel like it's doing what it's meant to do, with clear controls and valuable feedback to the player." [Pluralsight.com]

Perspective describes how the player sees the world on the screen. In war games, players usually have an aerial perspective above the battlefield. If the view is from directly above, like looking at a map, this is called a top-down perspective.

Levels means the stages. Levels should become tough gradually. It will help in making the flow of game. Games should be easy in beginning and gradually tougher. So that these could be enjoyed by novice and hard-core players equally.

Defining the player's role in the game world is a key part of defining your game's concept.

Games may have distinct modes, in which the nature of the gameplay changes significantly from one mode to the next. War games, for example, might have a

Some other elements cited by various websites are - Challenges, Rules, Gameplay, Victory Condition, Setting, Interaction Model, Perspective, Levels, The Player's Role, Modes, Structure and Realism.

Challenges means offering decision making situations to the player; putting player into a situation where he should act to proceed further else he will die.

When you decide to play any game, it's important to establish the rules in advance.

Game play means the way a player plays a game. So, offering various interactive situations will make the unique game play of everyone.

Victory Conditions or Goals and Sub Goals are meant to keep track of success and growth of the player. It gives mental satisfaction also to learn about one's progress.

Setting means the environment where a game is set. It is the theme which is made by color scheme, graphics and animation, sound and music of the game.

Interaction model means the way that the player interacts with the game world—takes actions to overcome the challenges. Two interaction models are particularly common in computer gaming. If the player plays in the game world by controlling a single character or pawn that represents him, and if that character exists and influence the area around him, that character is called his avatar.

strategic mode in which you plan which battles you intend to fight and a tactical mode in which you fight.

Structure means the flow chart of the game. The entire frame of game.

Game should depict the world even an imaginary one, in such a way that the principles of real-world logic and common sense apply. We cannot ignore real life principles in a game even if it is fictitious.

STUDY DETAILS

A study was done on 25 second year students of B.Sc. Animation and Multimedia course in an institute of Higher Education in Delhi NCR, India in January 2018. Firstly, for a month they were delivered lectures about elements of a digital game and basic concepts related to digital games were also discussed. At the end of January month, a

questionnaire was given to them which contained questions about their liking for elements in a game. These questions were of five-point likert scale. Out of total 25 respondents who happened to be of a Metro demographic background, there were 5 females and 20 male respondents. Their age group ranged from 19 to 21 years. They all have exposure to games on mobile phone. 6 of them play games 'daily', 8 play games 'rarely', 7 play games 'sometimes' and 4 play games 'very often'.

When asked how much important are the following elements of game on a five-point likert scale; meaning 1 value for least important and 5 for most important. When inputs given by respondents were added the following result was there:

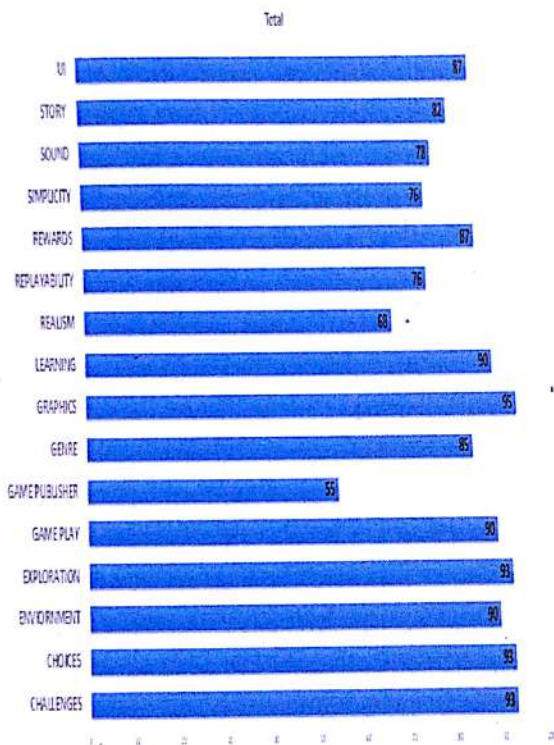

Figure: Bar graph showing which element of a Game attract them to what extent

- First rank: Graphics and Animation
- Second rank: Challenges, Choices offered in Game, Exploration
- Third Rank: Game Play, Game Environment or Ambience, Learning from Games
- Fourth Rank: User Interface, Rewards
- Fifth Rank: Genre of the Game
- Sixth Rank: Story

- Seventh Rank: Sound
- Eighth Rank: Simplicity of the Game and Replay-ability
- Ninth Rank – Realism
- Tenth Rank – Game Publisher

Games like Candy Crush Saga, Ludo king and Subway Surfers are the most popular games amongst the respondents.

Since this survey represents the opinions of a small segment and the sample size is also quite small but it gives a tentative idea to game developers and artists which they can keep in mind while making mobile games.

ABOUT THE POPULAR GAME AMONGST YOUNGSTERS



Image: Popular Mobile Games as liked by respondents

Candy Crush Saga, Ludo king, Asphalt Xtreme and Subway Surfers games are popular because of the following reasons:

Candy Crush Saga is a free-to-play match-three puzzle video game released by King on April 12, 2012, for Facebook; other versions for iOS, Android, Windows Phone, and Windows 10 followed. [Wikipedia] This game is popular because of its eye catchy graphics, music, puzzles and simple fluent game play which gets tougher gradually.

Ludo King is a cross platform game that supports Desktop, Android and iOS platform at same time in online multiplayer mode. Ludo game traces its lineage back to 6th century India. Ludo is derived from the game Pachisi. Ludo is also very similar to Spanish board game Parchís [Play.google.com] There are many similar versions of Ludo game are



available on app stores. People like this game because of its simple game play, multiplayer option and because its inspired from childhood game of everyone – the board game Ludo. Every Indian had played this game physically in their childhood.

Asphalt Xtreme is an offroad racer from Gameloft. You'll be racing on a variety of offroad tracks with a variety of vehicles. Currently, there are 35 vehicles that you can drive that cover seven distinct categories. Gameloft will likely add more to the game later. The .game also features online multiplayer racing

Released in 2012, Subway Surfers is an endless runner mobile game co-developed by Kiloo and SYBO Games, private companies based in Denmark. It is available on Android, iOS, Kindle, and Windows Phone platforms.It's an all-around polished and solid game that offers a lot of content for a simple infinite runner game.You have a number of characters, costumes, and cosmetic changes to choose from to add some flair to your game and give you a goal to shoot for while playing. The music is nothing too inspired, but it doesn't get in the way so that's nice. [Daniel Treccagnoli (2017)]

CONCLUSIONS AND RECOMMENDATIONS

Based upon this study, observation and literature review author gives the suggestions for game developers and designers for designing successful games. Although there is no formula for the success of a game yet the researcher believes that Game Play is the most essential element of a game. The intuitive, immersive game play can be created by a perfect mix of all other elements like graphics-animation, sound, story, interactivity etc. However, the result of this study has concluded that Graphics and Animation are most important for gamers which is also true because they set the look and feel of the game. This can be felt in all those games which have emerged as favorite games of respondents i.e. Candy Crush Saga, Ludo king and Subway Surfers games which are rich in graphics. It will be prudent to say that a perfect blend of all elements is required for the success of a game and how this perfect blend can be achieved is a skill which comes with experience and constant observation.

We can sum up with the words of designer RaphKester: -

“Games work best (at teaching) when the challenges are organic to the experience,rather than out of left field... just strapping an incentive structure on rote practicedoesn't work very well, compared to instead building a long-term goal structure, andthen presenting challenges on the way...”

REFERENCES

- [1] Mehta Niket, Dutta Suparna (2016), "Multimedia for Effective Communication", proceedings of International Conference on Signal Processing, Communication, Power and Embedded System (SCOPE5) – 2016 held from 3rd to 5th of October 2016 at Centurion University of Technology and Management (CUTM), Paralakhemundi Campus, Dist:Gajapati, Odisa, India. Link - <http://scopes.co.in/index.php/proceedings>
- [2] Mehta Niket, Dutta Suparna (2015), "Better Health Awareness through New Modes of Communication", paper presented at Global Academic Meeting 2015 at Jawaharlal University, New Delhi, 1-4 April 2015, published in European Scientific Journal (ESJ). Impact Factor - ICV 2013 = 8.25 (<http://eujournal.org/index.php/esj/issue/current>)
- [3] Mehta Niket, Dutta Suparna, BandyopadhyayAsit (2015), "Social Awareness Through New Media", International Journal of Emerging Technologies in Computational and Applied Sciences, Issue 11 Volume 3, December 2014-February 2015, pp. 258-261. Impact Factor – 1.237 (<http://iasir.net/journals.html>&https://issuu.com/iasir/docs/ijet_cas_issue_11_vol3-1)
- [4] Dutta Suparna, Mehta Niket (2014) "Inciting Gender Sensitivity through Digital Games – Humanity is needed to implement technology", paper presented at International conference on Frontiers of Infrastructure Finance organised by Vinod Gupta School of Management, Indian Institute of Technology, Kharagpur, India
- [5] Mehta Niket (2014), "Globalization and the World of New Digital Information Communication", Proceedings of UGC sponsored two days Media Summit "Media and Globalization" held on 20th & 21st February, 2014 at Kishen Chand Chela Ram College, Mumbai, ISBN 978-93-83842-64-3, Edited Book published by Excel India Publishers, New Delhi
- [6] Mehta Niket (2013), "Video Games as Learning &



- Communication tool for Teenagers in New Media Age*", ANVESHAK Journal, Pune, ISSN -2278-8913 (National Journal) [2013] (*ANVESHAK International Journal of Management (ISSN 2278-8913) is indexed in JIFACTOR at <http://www.jifactor.org/>, CiteFactor and J-Gate at <http://jgateplus.com/>*)
- [7] Mehta Niket (2013), "The Evolving Business of Digital Interactive Games in India", International Journal of Management and Behavioural Sciences VOL 2, NO.3, ISSN 2278-1285
- [8] Mehta Niket, Dutta Suparna, BandyopadhyayAsit (2013), "Video Games To Convey Serious Messages – A Study Using Food Force 2 Game", KIET International Journal of Communications & Electronics, KIET IJCE (ISSN: 2320-8996) [June 2013 [http://www.kietijce.org.in/uploads/IJCE%20\(Issue%20-%202\)%20-%202.pdf](http://www.kietijce.org.in/uploads/IJCE%20(Issue%20-%202)%20-%202.pdf)
- [9] Dutta Suparna, Mehta Niket, Pratik Rachana (2013), "Humane Digital Route to Customize Communication For Sustainable Development", 7th International Technology, Education and Development Conference [March 4th-6th, 2013, Valencia (Spain)] ISBN: 978-84-616-2661-8, ISSN: 2340-1079(Archive in Digital Library of IATED at <http://library.iated.org/view/DUTTA2013HUM>)
- [10] Dutta Suparna, Mehta Niket (2013), "Social Message through New Media", *Proceedings of International Conference on Computation and Communication Advancement (IC3A)-2013*, IEEE Kolkata Session, McGraw Hill publication, Page 341-344, organised by JIS College of Engineering, ISBN No.: 978-1-25-906393-0, 2013.
- [11] Mehta Niket (2012), "Digital Media- The New Language of Communication", ELTAI Conference Proceedings "Interfacing ELT with Culture and Technology Direction for New Classroom, Page 131-138, Edited Book published by Jain Brothers Publishers, New Delhi, ISBN: 978-81-8360-187-0, BITS Pilani, Department of Language and Communication,
- [12] Mehta Niket, Dutta Suparna, Tiwari Anuj, Hutchful David (2013), "Gaming as a Tool To Eradicate Female Foeticide In India", AICTE sponsored conference "Recent Trends in Computing, Mechatronics and Communication" at Om Institute of Technology, Hisar, Haryana, ISBN 978-81-923446-0-7
- [13] Parveen Pannu & Niket Mehta (23 June 2011), "E-Learning Games: Balancing Learning with Fun", presented at 19th Asian Media Information & Communication Centre (AMIC) Annual Conference "Technology and Culture: Communication Connectors and Dividers" 21-23 June 2010 organised by Suntec, Singapore at Sarojini Naidu School of Arts & Communication, University of Hyderabad. [Link](#)
- [14] Mehta Niket & Pannu Parveen (2011), "Relevance of Video Games in E-Learning in Convergent World", published in Proceedings of Conference on Higher Education at IIT Delhi
- [15] Mehta Niket (Feb 2011), "Video Games as ICT", published in proceedings of National Conference on Information Technology: Opportunities and challenges in 21st century", organised by BIT Noida Computer Science Department
- [16] What Makes a Great Game? The Key Elements of Successful Games, accessed from <https://www.pluralsight.com/blog/film-games/what-makes-a-great-game-the-key-elements-of-successful-games> on 30th Jan 2018
- [17] Econ.uiuc.edu, accessed from http://www.econ.uiuc.edu/~hrtdmr2/TTeaching/GT_2016_19/L1.pdf on 30th Jan 2018
- [18] Game Theory, Wikipedia, https://en.wikipedia.org/wiki/Game_theory
- [19] Chris Crawford (1982), The Art of Computer Game Design Digital Press, https://www.digitpress.com/library/books/book_art_of_computer_game_design.pdf
- [20] Chris Crawford (1982), The Art of Game Design, <http://www.vancouver.wsu.edu/fac/peabody/game-book/Chapter1.html>
- [21] Andrew Rollings et al (2009), Andrew Rollings and Ernest Adams on Game Design, Fundamentals of Game Design, New Riders Games
- [22] Ernest W Adams (), Teachers, Computers, games and Designers, accessed from <https://www.oecd.org/edu/ceeri/39414871.pdf> on 30th Jan 2018
- [23] Tracy Fullerton and Chris Swain (2014), Game Design Workshop, accessed from www.kinojabber.com/hk
- [24] Daniel Treccagnoli (2017), Subway Surfers: Surfing its way into my heart (Review), <http://www.androidguys.com/2017/01/15/subway-surfers-surfing-its-way-into-my-heart-review/>
- [25] Mehta Niket, accessed from <http://fundamentalsofgametechnology1.blogspot.in/2009/06/elements-of-game.html> on 30th Jan 2018.

Survey on Robotics and Wireless Sensor Network Integration

Snehal Kokare

Department of Electronics & Telecommunication
VPKBIET, Baramati, Savitribai Phule University, India
Snehal.kokare48@gmail.com

Abstract: Researcher have done lots of investigation in the area of robotics and wireless sensor network(WSN) independently, but if integrate this two areas then it would support to lots of application such as underwater, disaster management, nuclear power station, space exploration, military, healthcare etc. In this paper we start with review of WSN, robotics and how we could use robot in WSN. We can use robot to solve number of problems of wireless sensor network just like a localizing of nodes, and also robot can used as a data mules for aggregating data from different sensor nodes. We can also build a wireless sensor network using autonomous mobile robots instead of sensor node; the use of mobile robots gives accurate positioning. Received signal strength is used to get accurate position of mobile robots.

Keywords: Data mule, Localization, Mobile robot, Wireless Sensor Networks.

I. INTRODUCTION

Now days there has been lots of research takes place in wireless sensor network and it has various applications. In the robotics area, instead of single robot researcher moved to multiple robots and try to synchronize them using multiple algorithms such as a genetic algorithm and particle swarm optimization. In this paper firstly we describe what is mean by wireless sensor network. WSNs are networks of hundred to thousand sensor nodes; each sensor node is an embedded device which required very less power and that sensor nodes connected wirelessly by using different wireless protocol such as zigbee, Wi-Fi (Wireless-Fidelity) etc. These sensor nodes are distributed over a large area for monitoring environmental or physical conditions. Each node in the WSN has different functions according to the network topology. Few nodes are used sensing the environmental conditions; few nodes are used for routing i.e. for data aggregation. Data from all sensor nodes is collected at one particular node is termed as a 'sink node' [1]. Collected data by sensor node is aggregated wirelessly at sink node and then it sends to user through internet. Basic architecture of WSN is as shown in fig.1. Wireless sensor network can be

classified into two types Unstructured WSN and Structured WSN.

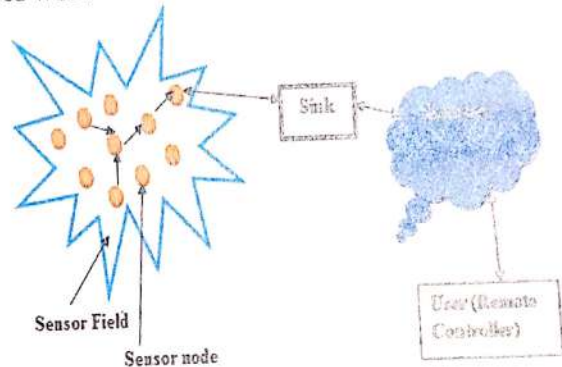

Fig. 1 Architecture of wireless sensor network

In unstructured WSN nodes are deployed randomly in ad-hoc manner over a large area. In structured mode nodes placement are preplanned; at the time maintenance structured mode is easy as compare to unstructured mode [2] [3].

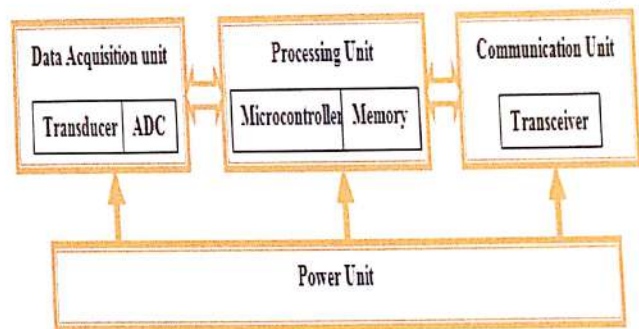

Fig.2 Wireless sensor node

Figure 2 shows basic structure of sensor node. Generally sensor node contains data acquisition module for collecting the physical data, Processor, Communication module and power module for giving power to this entire module. Transducer is present in

data acquisition module which is used for convert the physical signal into its equivalent analog signal; then Analog to Digital Converter (ADC) is used for obtaining digital signal which is needed for processor module. Stored data in memory unit is processed by microcontroller and send control signal to communication module for further communication in between sensor nodes. Power unit may be solar cell or batteries. Power unit is used to determine the size of the mote. We can add different component in sensor node structure depending upon the requirement of applications. For example if we need location information then adds Global Positioning System (GPS) module in node structure [4] [5].

In WSN there are several issues such as a network topology selection, path selection for data transmission from one sensor node to another node, for wireless transmission which protocol is beneficial? Is that protocol is energy efficient or not. What is data transmission rate? Selection of sink node and if the nodes in WSN are static then at the time of data aggregation several issues occurred. Autonomous robot help the WSN in multiple ways, it enhance the capabilities of WSN. It helps for deploying the node, aggregating data, localizing node, it can act as a sensor node.

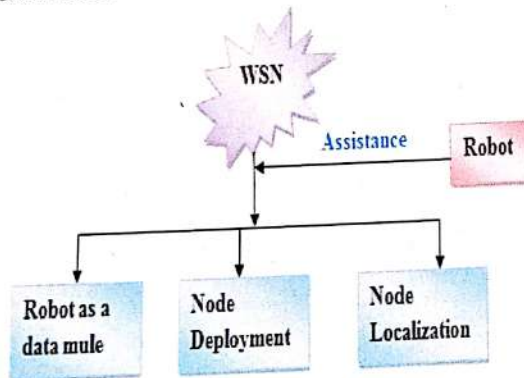

Fig. 3 WSN assisted by mobile robot

II. Robot as a Data Mules

In WSN there are two types of sensor nodes i.e. static sensor node and mobile sensor node. Mobile sensor node based WSN has more advantages over the static sensor node based WSN but its cost is more; so depend upon applications we have to choose sensor nodes. If we go to static sensor nodes then there are issues occur at the time data aggregation. For these issues Giuseppe Anastasi et.al used mobile robot to collect data from various static sensor node and it is termed as 'Data mule'. Mobile robot visits the various sensor nodes after certain time for pick up the data and

sends it to Access Point (AP). Most of the time sensor node is sleeping mode for energy conservation and at that instant if mobile robot arrives to pick up the data from sensor node then it miss the mobile robot passage; so sensor node has to wait until the next iteration of mobile robot. In this scenario energy conservation is pointless [6].

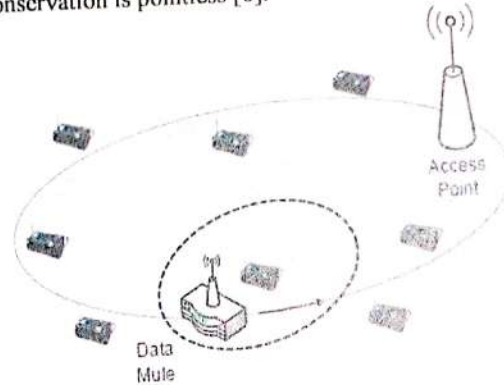

Fig.3 Data mule architecture [6]

III. Localization Nodes Using Robot in a WSN

In some dangerous area such as nuclear power station, military manual sensor node placement is not possible; so HAI Dan et.al proposed method in that a robot fitted with GPS (Global Positioning System) module is used to place the node. Received Signal Strength Indication (RSSI) is used to estimate the distance between neighboring sensor nodes and also RSSI used estimate the distance between mobile robot and each sensor node; this would help to localize the node[6]. This method is illustrated in Fig.4.

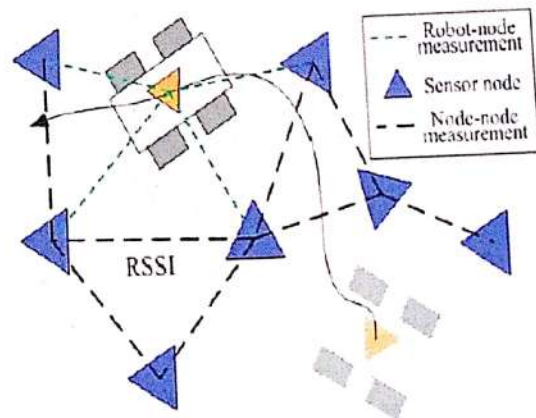

Fig. 4 Localization Scenario [5]

IV. WSN Based on Multi-Mobile Robot

Mobile robots perform the task in the dangerous area where human cannot work such as disaster management, drainage system, Coal mine etc. We can use mobile robot to perform some boring and repetitive task. In WSN instead of sensor node if we use Mobile robots to monitor environmental condition and for collecting a real world data then it would be beneficial. Robots mainly consist of microcontrollers, sensors, actuators and motors. Robots navigate through the area for collecting and routing the data packets. In multi-robot system coordination between these robots is one of the main issues. To solve this issue use master slave architecture, where one of the robots is master and all others are slave. Master robot takes the decision and all others follow it [7][8]. Every slave robot receives command from master robot and performs actions accordingly. In multi-robot architecture few one collects data, few robots is used for routing the data packet [9].

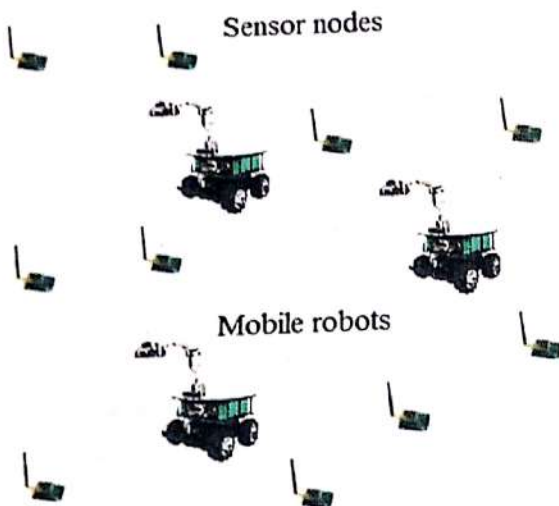

Fig. 5 WSN based on multi-mobile robot [10]

V. CONCLUSION

In this paper we make the survey of how can we use mobile robot in WSN; and also we discussed issues. If we integrate WSN and robotics then there is a huge application many more problems get solve. Merging of these two fields may replace the human presence in dangerous area. By using mobile robot data collection

might be improved; but it is challenging to maintain the co-ordination between multiple mobile robots.

VI. REFERENCES

- [1] Daniel Ioan curiac, "Towards Wireless Sensor, Actuator, and Robot Networks: Conceptual Framework, Challenges and Perspectives", *Journal of Network and Computer Applications*, vol.63, pp-14-23, Jan. 2016.
- [2] Sudhir B. Lande, Sushil Z. Kawle, "Review on Energy Efficient Using Clustering Algorithm for Wireless Sensor Network", *KIET International Journal of Communications and Electronics*, Vol.3, Issue No. 2, Jul.2015, ISSN: 2320-8996.
- [3] Hui Lin, Halit Uster, "Exact and Heuristic Algorithms for Data Gathering Cluster Based Wireless Sensor Network Design Problem", *IEEE Trans. On Networking*, Vol.22, pp.-903-916, June 2014.
- [4] T.Kalaiyani, P.Priya, A.Allirani, "A Survey on Zigbee Based Wireless Sensor Networks in Agriculture", *IEEE Conference*, 2011.
- [5] Sam Shue, James M. Conrad, "A Survey of Robotic Applications in Wireless Sensor Network", *IEEE Conference*, 2013.
- [6] Giuseppe Anastasi, Macro Conti, Mario Di Francesco, "Data Collection in Sensor Node with Data Mules: An Integrated Simulation Analysis", *IEEE Conference on Computer and Communication*, Italy, July 2008.
- [7] Shuxiang Guo, Xin Li, Jian Guo, "Study on a Multi Robot Wireless Communication Control System for the Spherical Amphibious Robot", *IEEE Conference on Mechatronics and Automation*, China, Aug.2016.
- [8] R.Kazala, A.Taneva, M.Petrov, St. Penkov, "Wireless Network for Mobile Robot Applications", *Elsevier International Federation of Automatic Control*, Poland, pp.231-236, 2015.
- [9] Victor Ababit, Viorica Sudacevschi, Marin Podubnii, Irina Cojuhari, "Sensors Network Based on Mobile Robots", *International Conference on Development and Application System*, Romania, May 2014.
- [10] Gurkan Tuna, Vebbi Cargi, Gungor, Stelios, M. Potirakis, "Wireless Sensor Network Based Communication For Co-operative Simultaneous Localization and Mapping", *Journal Computer and Electrical Engineering*, Vol.41, pp.407-425, April.2015.

Performance Analysis of Solar Cells for Low-Power Energy Harvesting Wireless Embedded Systems

Himanshu Sharma¹, Ahteshamul Haque², Prince Sachan³, Mayank Sharma⁴
^{1,3,4} KIET Group of Institutions, Ghaziabad, U.P. India
² Jamia Millia Islamia, New Delhi

Abstract:-In this paper, we analyse the performance of low-power energy harvesting solar cells for wireless embedded devices like wireless sensor networks (WSN) nodes. The average cell efficiency of a solar panel is between 10 – 20% worldwide. From our analysis, it is clear that the system efficiency of GaAs material solar cells is highest (24.10 %) as compared to all other solar cells.

Keywords:- Solar Cells, Energy Harvesting, Wireless Sensor Nodes

1. Introduction:

The solar energy harvesting wireless sensor networks (SEH-WSN) are used for monitoring and control applications such as light, temperature, humidity, pressure, acceleration of the industrial plants, smart cities, farms, forests, greenhouses and remote locations. The conventional Wireless Sensor Networks (WSNs) has the design limitation of high power consumption during their operation, which has been tackled by mainly duty cycle based approach till now [1]. In this paper, we propose and survey the solar energy harvesting technique as a new design solution for the energy constrained WSN nodes [2]. The solar photovoltaic (PV) energy harvesting refers to converting solar light energy into electrical energy to operate an electrical or electronic device. As applied to WSNs, the solar

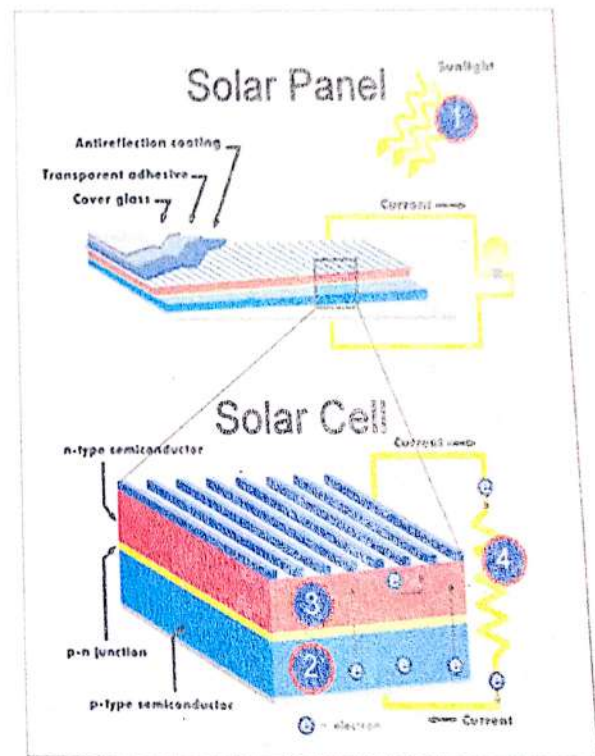

Fig.1 A Solar Cell inside the Solar Panel

light energy is converted into electrical energy and is utilized to recharge the battery of a WSN node at the operation site itself. Therefore, no need for battery replacement repeatedly once the battery energy has been discharged (as such happens in the conventional non-rechargeable battery based WSNs). The electrical energy harvested from solar energy (sunlight) can also be used directly to power a WSN node. Alternatively, the collected energy may be warehoused in a rechargeable battery (or

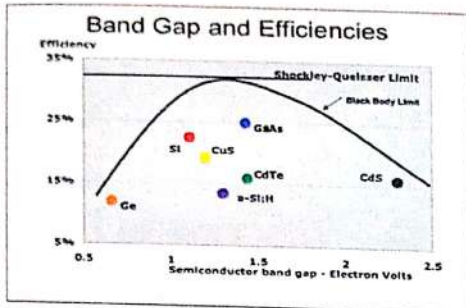

Fig.2 Band Gap and Efficiencies of various semiconductors used for solar cells

supercapacitor) for the future purpose (e.g. during nighttime when sunlight is not available). The SEH-WSNs consists of small autonomous WSN nodes attached to small size solar panels for their energy harvesting needs. The fig.1 shows a solar cell constructed inside the solar panel. A number of solar cells are connected in series-parallel combination to achieve the desired output voltage e.g. 3volts, 6 volts, 9 volts, 12 volts 48 volts and so on. The fig.2 shows the energy band gap (electron volts) and efficiency of various materials chosen for construction of solar cells. Clearly, the efficiency of GaAs material solar cells is highest 30% (theoretically) at the band gap of 1.24eV. The main design challenges at solar energy harvesting level in Solar Energy Harvesting Wireless Sensor Networks (SEH-WSN) are as follows:

- All the light energy coming from sunlight rays should be fully utilized. The SEH-WSN node should use solar energy as primary source and rechargeable battery energy as the secondary source.
- To expand the battery charging-discharging life cycle.

- Designing of simple and inventive solar charger
- To shrink the overall power use.
- To enhance the stability of the overall SEH-WSN system.
- Energy harvester circuits should be compatible existing WSN industry communication standards like IEEE 802.15.4 (ZigBee) and IEEE 1451.5 standards.
- To achieve the highest power from the sun.
- To ensure small power consumption for DC-DC Boost converter operation.
- To convey maximum power to the SEH-WSN node using the harvested energy.
- To start-up (or bootstrap) the SEH-WSNnode.
- Variations in solar radiation level, Solar Cell efficiency (η), DC-DC converter design, MPPT design and Energy Prediction Algorithms.
- Cost Effective energy harvesting solutions (cheaper than battery replacement cost)

Pertaining to the use of solar energy to power WSNs, a lot of researchers have done a lot of research work. But still, there are many design challenges in SEH-WSNs which need to be explored for further optimization. Solar panels are given a power rating in Watts, based on the amount of electricity they can produce in one hour of peak sunlight. However, these ratings are classified under ideal conditions in a laboratory, and therefore don't represent the amount of power that could be expected of that panel on a day-to-day basis. So a 250mW panel is not going to produce 250 mW of electricity, even in peak sun.

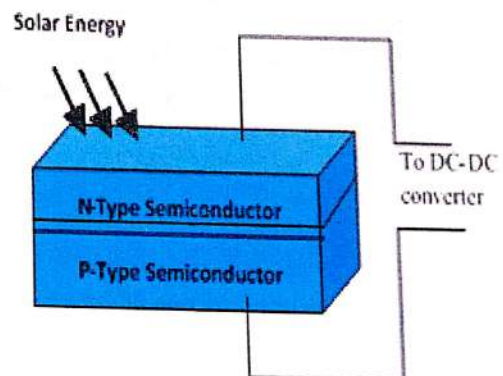

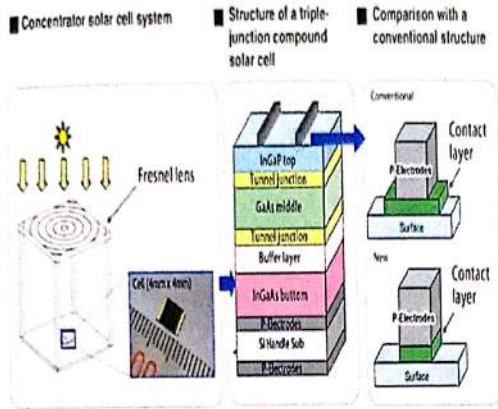

Fig.4 Concentrator System for a Heterojunction

The fig. 4 shows the concentrator System for a Heterojunction solar cell which consists of different types of semiconductor layers to increase the overall efficiency. Here, the materials used in heterojunction solar cell are Ga solar cell's energy conversion efficiency is the percentage of power converted from sunlight to electrical energy under "standard test conditions" (STC). Solar cell efficiency refers to the portion of energy in the form of sunlight that can be GaAs, InGaAs and silicon semiconductors converted via photovoltaics into electricity. A Solar Cell is a semiconductor PN junction made from Si, GaAs or CdTe. The basic solar cell construction is shown in fig.3. It consists of N-type and P-type silicon semiconductors. The solar cell symbol is shown in fig.5. The solar cell equivalent circuit consists of a current source, a diode, and two resistances (series and shunt) connected as shown in fig.6.

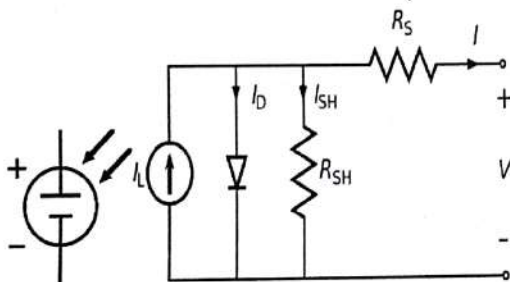

Fig. 5. Symbol of Solar Cell

Fig. 6. Equivalent circuit of Solar Cell

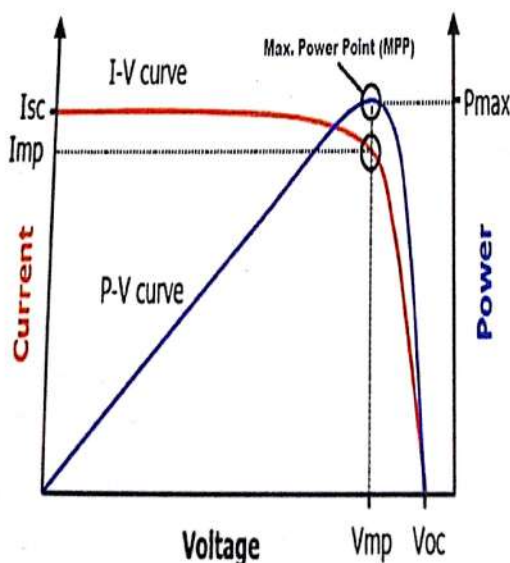

Fig. 7. V-I and P-V Characteristics

Fig.7 shows the Voltage current (V-I) and Power Voltage (P-V) characteristics of a solar cell. There are various parameters in these characteristics like Open Circuit Voltage (V_{oc}), Short Circuit Current (I_{sc}), Max. Voltage (V_m), Max. Current (I_m) and max. power point are shown. Mathematically, the current equation of a solar cell is given as:

$$I = I_L - I_o \left(\exp\left(\frac{V}{V_T}\right) - 1 \right) \quad (1)$$

Where, I = Output current from solar cell, V = Diode voltage, Thermal Voltage (V_T) = kT/q , I_L = Light photons generated current, and I_o = Reverse saturation current. At room temperature (300K), the thermal voltage is equal to 0.0259 volts (or ~26 mV). The ability



of the solar cell to convert light energy into electrical energy is called conversion efficiency and given as:

$$\text{Efficiency } (\eta) = \frac{FF \cdot V_{oc} \cdot I_{sc}}{P_i} \quad (2)$$

the maximum power can be extracted from the solar cell. Ideally, the solar cell efficiency should be high. But practically, it is limited to 5 - 15% only.

2. Literature Survey of solar (PV) cell Efficiency:

The main research issue is Optical to electrical energy conversion efficiency (η) which is tackled by choice of suitable construction materials. Ian Mathews et al.²⁰ have shown that column III-V solar cells (GaAs, GaInP) are better than amorphous Silicon (a-Si) solar cells. At low radiation levels, the power density of GaAs and GaInP solar cells is twice as compared to a-Si solar cells. Jung-Chuan Chou et al.²¹ have shown the result of various Graphene Oxide (GO) materials on Dye-Sensitized Solar Cells (DSSCs). They obtained the optimal photoelectric conversion efficiency (η) of 5.26% using graphene material.

Li Cai and Ajeet Rohatgi[10] have investigated the effect of Post-Plasma Enhanced Chemical Vapor Deposition (PECVD) photo-assisted anneal over multi-crystalline silicon (mc-Si) solar cells. Shih-Yung Lo et al.[11] have shown fabrication of flexible Amorphous-Si (a-Si) thin-film solar cells over a parylene pattern using a direct separation process. Luigi Vesce et al.[12] have shown the formulation, implementation, and processing of the catalyst layers in monolithic dye-sensitized solar cells. Valerie Depauw et al.[13] have shown that the two-dimensional photonic crystals (2DPC) are a potential approach to maximize the light absorption in the active region of solar cells. A company named Sanyo Electric Company Ltd., a subsidiary of Panasonic, Japan manufactures volts with a short circuit current (I_{sc}) of 20 μ A.

Where, FF = Fill Factor, V_{oc} is Open Circuit Voltage, I_{sc} is Short Circuit Current, and P_i is incident optical power. The maximum power point (MPP) is a point on the Power voltage (P-V) characteristic of the solar cell, where

For outdoor applications, the AM-5608CAR solar module which is a 60 x 41 mm amorphous silicon solar cell that produces 5 V and ISC of 18 mA, is used to power a WSN node.

The efficiency of various solar cells has been compared in Table I. It compares the performances of Amorphous, Crystalline, and Polycrystalline Silicon, Dye-Sensitized, GaAs and Perovskite (CaTiO_3) solar cells. The efficiency of DSSC is computed from small size solar cells of 1cm^2 each which is considered to be 10-20% high as compared to big-size cells. Here, the unit efficiency η_{cell} (%) refers to single solar cell efficiency and system efficiency η_{panel} (%) means complete PV panel efficiency. Generally, the system efficiency is less than unit efficiency due to various interconnection losses of solar cells in a panel as shown in Table I. From the comparison table I, it is clear that the system efficiency of GaAs solar cells is highest (24.10 %) as compared to all other solar cells. But the manufacturing cost of GaAs solar cells is very high. Therefore, if we take trade-off between cost and efficiency then DSSC is the best choice having efficiency 22.74 %.

3. Solar Cell Efficiency Calculations:

$$\eta = \frac{P_{max}}{E \cdot A_c} \times 100 \% \quad \dots(3)$$

Where,

P_{max} . = Max. power output (watts)

E= Incident radiation flux (Watts/ m^2)

A_c = Area of Collector (m^2)

PV System Efficiency

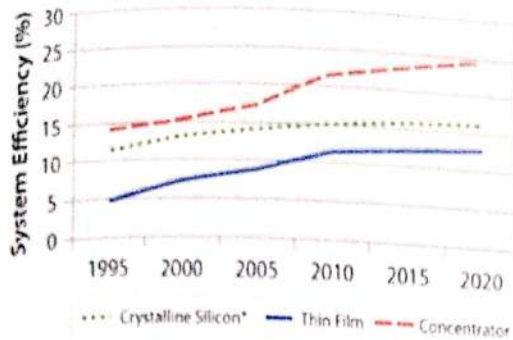

Fig. 8 PV system efficiency

manufacturer's panel will perform within 3% of its Watts rating.

- **The effect of dirt on solar panels:**
 Dirt and grime also affect the efficiency of a solar panel. This varies from panel to panel, however, it's best to factor in a loss of performance. In all of our calculations, we equate the loss of efficiency due to dirt and grime to be 5%. If you were to clean your panels regularly, they would perform better.

Sr. no.	Type of Solar Cell	No. of Cells in Panel	Open Circuit Voltage, V_{oc} (V)	Short Circuit Current, I_{sc} (μA)	Dimension (cm)	Area of Unit Cell (cm^2)	Total Area of Panel (cm^2)	Power Density At MPP ($\mu W/cm^2$)	Unit Efficiency η_{cell} (%)	System Efficiency η_{panel} (%)
1	Crystalline Silicon	8	2.0	699.56	7.7 1.2	9.24	73.12	7.91	10.22	9.10
2	Polycrystalline Silicon	8	1.5	319.07	5.6 1	5.6	44.8	3.99	5.16	4.54
3	Amorphous Silicon	9	2.89	233.35	5.2 0.61	3.18	28.62	12.07	15.59	14.03
4	Dye-Sensitized solar cell (DSSC)	4 (parallel)	0.6	194.41	1 1	1	4	22.0	28.42	22.74
5	GaAs	1	0.90	-	- -	8.55	8.55	26.07	28.03	24.10
6	Perovskite ($CaTiO_3$)	1	0.71	200.08	- -	5.44	5.44	19.32	20.4	17.34

Table 1: Solar Cell Efficiency Comparison:

The system efficiency of three main types of solar cells is (crystalline silicon, Thin film and concentrator) solar cells is shown in fig.8. Here, the solar cells efficiency using sunlight concentrators over the solar cells is the highest up to 25% theoretically.

4. **Factors that affect the efficiency and output of a solar panel:**

There are several factors that affect the panel output and efficiency of a solar panel. All of these factors must be considered when calculating solar power at any given location.

- **Manufacturer's output tolerance:**

Most solar panels have an output tolerance +/- 3%, which means that the

- **Temperature derating:**
 Solar panels are affected by temperature. If the temperature is increased, then the efficiency of the solar panel is decreased and vice-versa.
- **Orientation Angle:**
 The direction that solar panels face, and the angle that they are mounted, also have an affect on the output of the panel. If they are not positioned at the optimum angle and direction, then the panels will not produce rated output for that location. This is a must when accurately calculating solar output.
- **DC-DC Converter efficiency:**
 The DC-DC Converter converts Direct Current (DC) at one voltage level into another DC voltage level. This process is not

100% efficient. Whilst DC-DC Converter efficiency technology is improving, it can still account for as much as an loss in efficiency. We allow for an average of 5% loss in all of our calculations.

• **Rechargeable Battery Efficiency:**

If we have a hybrid system with a solar battery, the battery will not operate at its rated Wattage or power capacity always.

• **Commercial Aspects:** The most efficient commercially available solar panels on the market today have efficiency ratings as high as 22.5%, whereas the majority of panels range from 14% to 16% efficiency rating. SunPower panels are known for being the most efficient solar panel brand available on the market. Though they will come with a higher price tag, SunPower will often be the consumer favourite for anyone concerned with efficiency as a primal metric of interest.

5. Results and Conclusion:

In this paper, the design challenges of solar energy harvesting and efficiency of various solar cells have been analysed for low power energy harvesting applications like wireless sensor networks. From the comparison table I, it is clear that the system efficiency of GaAs solar cells is highest (24.10 %) as compared to all other solar cells. But the manufacturing cost of GaAs solar cells is very high. Therefore, if we take trade-off between cost and efficiency then DSSC is the best choice having efficiency 22.74 %.

References:

[1]. Akyildiz I.F., W. Su, Y. Sankarasubramaniam, E. Cayirci, "Wireless sensor networks: a survey", Computer Networks, Elsevier 38, 393-422 (2002).
[2]. Sujesha Sudevalayam and Purushottam Kulkarni, "Energy Harvesting Sensor Nodes: Survey and Implications", IEEE Communications Surveys & Tutorials 13(3), 443-461 (2011).

[3]. National Renewable Energy Laboratory (NREL), U.S. Department of Energy, Golden, Colorado, USA [https://www.nrel.gov].
[4]. M. Rasheduzzaman, P. B. Pillai, A. N. C. Mendoza, and M. M. De Souza, "A study of the performance of solar cells for indoor autonomous wireless sensors," IEEE 10th International Symposium on Communication Systems, Networks and Digital Signal Processing (CSNDSP), pp. 1-6, IEEE, 2016.
[5]. Martin A. Green, Keith Emery, Yoshihiro Hishikawa, Wilhelm Warta and Ewan D. Dunlop, "Solar cell efficiency tables (version 47)", Journal of Progress in photovoltaics: research and applications, Volume 24, Issue 1, 24 Nov. 2015, Wiley Online Library [Available online] <http://onlinelibrary.wiley.com/doi/10.1002/pip.2728/pdf>.
[6]. Himanshu Sharma, Ahteshamul Haque, and Zainul A. Jaffery "Solar energy harvesting wireless sensor network nodes: A survey", Journal of Renewable and Sustainable Energy, published by American Institute of Physics (AIP), USA, vol.10, no.2, pp 1-33, March 2018.(SCI Journal, Impact Factor: 2.14). [Available online: <https://doi.org/10.1063/1.5006619>]
[7]. Himanshu Sharma, Ahteshamul Haque, Zainul Abidin Jaffery, "Design Challenges in Solar Energy Harvesting Wireless Sensor Networks" Nanotechnology for Instrumentation and Measurement (NANOFIM) Workshop, 3rd IEEE International Conference, Gautam Budh University (GBU), Greater Noida, November 16, 2017.
[8]. Himanshu Sharma, Pooja Agarwal, "A survey of Energy Harvesting Techniques for Wireless sensor Networks" AKGEC International Journal of Technology, vol.8, issue 1, pp.6, June 2017.
[9]. Himanshu Sharma, Rohit Tiwari, "Industrial Wireless Sensor Networks (IWSN): Design and Challenges", IOSR Journal of Electronics and Communication Engineering (IOSR-JECE), ISSN: 2278-2834, volume 11, issue 4, ver.1, DOI:10.9790/2834-1104, Aug.2016.(UGC approved Journal)
[10]. Li Cai and Ajeet Rohatgi, "Effect of Post-PECVD Photo-Assisted Anneal on Multicrystalline Silicon Solar Cells", IEEE

Transactions on electrondevices, 44(1), 97-102 (1997).

- [11]. Shih-Yung Lo, Dong-Sing Wu, Chia-Hao Chang, Chao-Chun Wang, Shui-Yang Lien, and Ray-Hua Horng, "Fabrication of Flexible Amorphous-Si Thin-Film Solar Cells on a Parylene Template Using a Direct Separation Process", IEEE Transactions on Electron Devices, 58(5),1433-1438 (2011).
- [12]. Luigi Vesce, Riccardo Riccitelli, Girolamo Mincuzzi, Alessio Orabona, Giuseppe Soscia, Thomas M. Brown, Aldo Di Carlo, "Fabrication of Spacer and Catalytic Layers in Monolithic Dye-Sensitized Solar Cells, IEEE Journal of Photovoltaics, 3(3), 1004-1011 (2013).
- [13]. Valerie Depauw, Xianqin Meng, Ounsi El Daif, Guillaume Gomard, Loïc Lalouat, Emmanuel Drouard, Christos Trompoukis, Alain Fave, Christian Seassal, and Ivan Gordon, "Micrometer-Thin Crystalline-Silicon Solar Cells Integrating Numerically Optimized 2-D Photonic Crystals", IEEE Journal of Photovoltaics, 41, 215-223 (2014).

A STUDY ON TRANSCONDUCTANCE OF MICRONSCALE n-MOSFET USING HSPICE

Tejashri mane^{#1}, Milan Sasmal^{*2},

¹maneteju11994@gmail.com

Abstract— In this paper we studied I-V characteristics of MOSFET. Then studied the graph of transconductance Vs drain current. Lastly, we investigate effect of channel length and width on transconductance. For that channel length is vary from 10um to 40um.drain voltage is taken as 5V.gate voltage varies from 1V to 4V.see the effect of channel length and width on parameter of MOSFET

Keywords— Drain Voltage, Drian curret, Channel length, Channel width, MOSFET, Transconductance.

I. INTRODUCTION

One of the most important parameter for the characterization of the operation of a MOSFET is transconductance. The channel length (L) channel widths (W) are two important parameters for modelling and characterization of Metal Oxide Semiconductor Field Effect Transistor (MOSFET). Channel length is most important key device parameter, which is the distance between n^+ - p junction. Threshold voltage is nothing but the gate voltage at which an inversion layer forms at the interface between the insulating layer and the substrate of the transistor [1]. The purpose of the inversion layer's forming is to allow the flow of electrons through the gate-source junction. Therefore, threshold voltage represents the onset of significant drain current flow which also depends on channel length. In addition, threshold voltage plays an important role for the determination of device operation regimes which can be divided into three operational regions First, if the threshold voltage is less than the gate voltage (V_{gs}), the inversion charge density is large enough to operate the device in the strong inversion region where drift current is dominant[2]. Second, if V_{th} is greater than V_{gs} , the inversion charge density is smaller than substrate doping concentration which compels the device to operate in the weak inversion region so diffusion current becomes dominant[5]. Lastly, if V_{th} is very close to V_{gs} , the inversion charge density is such that the device operates

in the transition region where both diffusion and drift currents are important. Analysis of MOSFET circuits is based on three possible operating modes: cutoff, triode (aka linear), and saturation. In cutoff, the gate-to-source voltage is not greater than the threshold voltage, and the MOSFET is inactive [4]. In triode, the gate-to-source voltage is high enough to allow current flow from drain to source, and the nature of the induced channel is such that the magnitude of the drain current is influenced by the gate-to-source voltage and the drain-to-source voltage [3]. As the drain-to-source voltage increases, the triode region transitions to the saturation region, in which drain current is (ideally) independent of drain-to-source voltage and thus influenced only by the physical characteristics of the FET and the gate-to-source voltage.

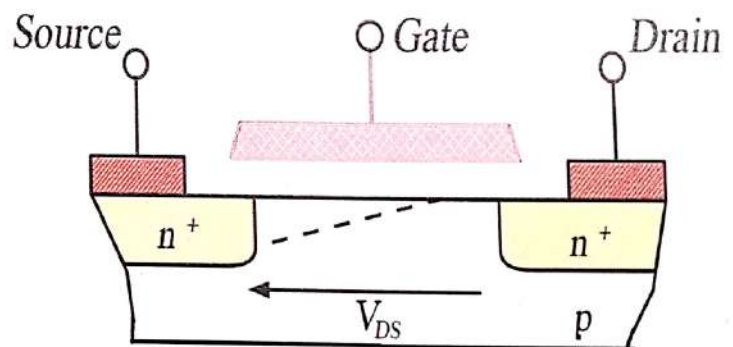

Fig.1:-Schematic representation of N channel MOSFET

Analysis of MOSFET circuits is based on three possible operating modes: cutoff, triode (aka linear), and saturation. The subthreshold region is a fourth mode, but we don't need to worry about that for this article [11]. In cutoff, the gate-to-source voltage is not greater than the threshold voltage, and the MOSFET is inactive. In triode, the gate-to-source voltage is high enough to allow current flow from drain to source, and the nature of the induced channel is such that the magnitude of the drain current is influenced by the gate-to-source voltage and the drain-to-source voltage [7-8]. As the drain-to-source voltage increases, the triode region transitions to

the saturation region, in which drain current is (ideally) independent of drain-to-source voltage and thus influenced only by the physical characteristics of the MOSFET and the gate-to-source voltage [9].

Structure Model

$$i_d = k_n' \frac{W}{L} (V_{GS} - V_{TH}) v_{gs}$$

$$g_m = \frac{i_d}{v_{gs}}$$

$$g_m = k_n' \frac{W}{L} (V_{GS} - V_{TH}) \dots [1]$$

Transconductance is a measure of how strong the drain current changes when the gate voltage changes. Transconductance (g_m) is a measure of how much the drain current changes when the gate voltage changes. For MOSFET applications, the MOSFET is usually operating in the saturation region.

$$g_m \equiv \frac{\partial I_D}{\partial V_{GS}}$$

For a long-channel MOSFET:

$$g_m = \mu_n C_{ox} \frac{W}{L} (V_{GS} - V_{TH}) \{1 + \lambda(V_{DS} - V_{D,sat})\}$$

$$g_m = \sqrt{2\mu_n C_{ox} \frac{W}{L} \{1 + \lambda(V_{DS} - V_{D,sat})\} I_D}$$

For a short-channel MOSFET

$$g_m = v_{sat} WC_{ox} \{1 + \lambda(V_{DS} - V_{D,sat})\}$$

- gm= Transconductance
- μ_n =Surface
- Cox=Oxide thickness
- W=width
- L=length

II. RESULTS AND DISCUSSION

Here in this paper firstly we studied the I-V characteristics of MOSFET. In this graph we observed that when drain voltage increase drain current is increases. There is effect of drain and gate voltage on the drain current. When gate voltage increases then it show effect on the drain current also. In this graph gate

voltage is apply as 1V, 2V, 3V, 4V respectively. Drain voltage is applied as 5V. From this graph we see the effect of voltages on drain current.

Here to get the result we used the Hspice software. This is circuit simulator from that can see behaviour of circuit parameter. This is the main thing of the simulator. Origin software is also use for plotting the data. Whatever data extracted from Hspice software that plot in the origin tool. Tranconconductance is one of the most important parameter of mosfet. If the substrate is at a different voltage than the source, the threshold voltage varies due to the pn junction between source and bulk. For this lab, the source and bulk will be tied together, so this effect will be ignored.

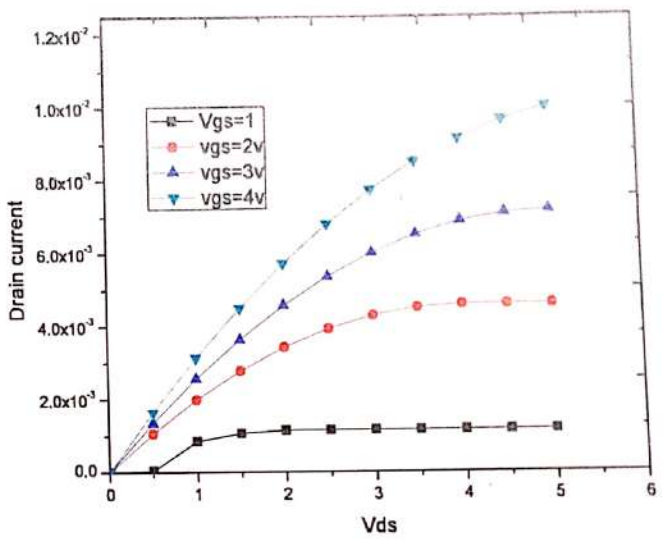

Fig.2:-ID-VDS characteristics of an n-channel MOSFET

This is the graph of transconductance Vs drain voltage. In which we can see that when drain voltage increases transconductance is also increases but after saturation region transconductance remain same there is no change in transconductance. Transconductance is a measure of how strong the drain current changes when the gate voltage changes. Here gate voltage applied from 1V, 2V, 3V 4V,5V respectively. At high drain voltage transconductance is also high. This is the relation of transconductance with the drain voltage

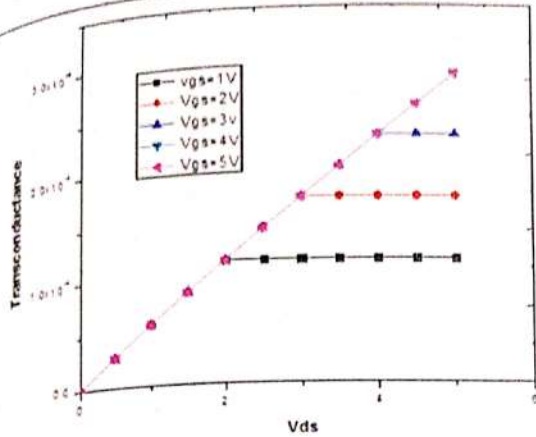

Fig 3:-GM-VDS characteristics of an n-channel MOSFET

Now the main part of the paper is see the effect of channel length and width on transconductance. In which we can see the effect of change in channel length on transconductance. For that channel length is varies from 10um to 40um and width is constant. For width is varies from 10um to 40um and channel length keep constant 60um. From the graph we see the effect of channel length and width on transconductance (gm).

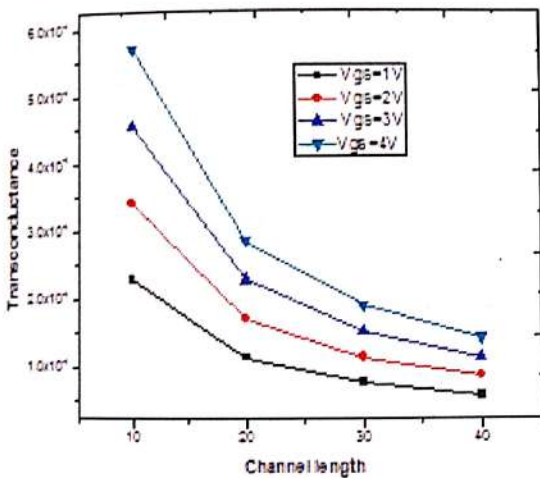

Fig 4:-Channel length Vs transconductance.

Here in this graph channel length is varies from 10um, 20um, 30um, 40um respectively. And channel width is kept constant as 60um. Gate voltage is varies from 1V, 2V, 3V, 4V respectively. Drain voltage keep constant as Vds=5V. from this we conclude that as channel length increases transconductance is decreases. Channel length is inversely proportional to the transconductance

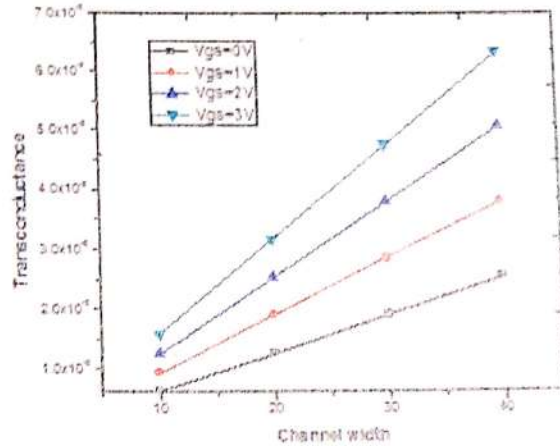

Fig 5:-Channel width Vs transconductance.

Here in this we also investigate the effect of channel width on transconductance. For this case also channel width is varies from 10um, 20um, 30um, 40um respectively. Gate voltage is also varies from 1V, 2V, 3V, 4V respectively. Drain voltage kept constant for all gate voltages. In this graph channel width transconductance increases. At minimum channel length transconductance is maximum.

III. CONCLUSION

We investigate I_d - V_{ds} characterization of Silicon n-MOSFET at room temperature by showing the effects of channel length and channel width on transconductance and investigating the effect of V_{gs} and V_{ds} also. The simulation results obtained in this work are compatible with analytical model of 1 Si n-MOS.

IV. REFERENCES

- [1] Yuan Taur; Jianzhi Wu; Jie Min et.al Digital Circuits Transient Analysis, Parasitic, and Scalability”, IEEE Transactions On Electron Devices, Vol. 53, NO. 11, Nov-2016.
- [2] Y.M. Lin et al., High-Performance Metal Oxide Field-Effect Transistor With Tunable Polarities, IEEE Trans. on Nanotech, Vol. 4, No. 5, pp. 481-489, Dec 2015.
- [3] Aamir Ahmad, Guilherme Lawless, and Pedro Lima, Member, IEEE , EFFECT OF THRESHOLD VOLTAGE AND CHANNEL LENGTH ON DRAIN CURRENT OF SILICON N-MOSFET, May 6, 2017.
- [4] Sakurai, T., Newton, A. R. A simple MOSFET model for circuit analysis. IEEE Trans. Electron Devices, vol. 38, no. 4, pp. 887-894. June 2016.

- [5] Kwang-Sub Shin , Jae-Hoon Lee, Sang-Myeon Han, In-Hyuk Song, Min- Koo Han Elsevier Effect of channel length on the threshold voltage degradation of hydrogenated amorphous silicon TFTs due to the drain bias stress V1.10 2015-04-23.
- [6] Min-Gu Lee; Sunggu Lee, "Compact modelling for drain current of short channel MOSFETs including source/drain resistance effect" IEEE Transaction, Volume: 2 Pages: 930 - 934 vol.2,year: 2014.
- [7] QT.Morteza, Yusofl.et.al A Compact Short- Channel Model for Symmetric Double-Gate TMDFET in Subthreshold Region, IEEE Transaction on Electronic Devices Volume: 63, Issue: 6, June 2016.
- [8] Gupta, A., Mishra, D.K., Khatri, R., Chandrawat, U.B.S. and Jain, P. (2010), "A Two Stage and Three Stage CMOS OPAMP with Fast Settling, High DC Gain and Low Power Designed in 180nm Technology," in *Computer Information Systems and Industrial Management Applications (CISIM)*, 2010 International Conference on , pp. 448–453, 8-10 Oct. 2010 doi: 10.1109/CISIM.2010.5643497.
- [9] Qiang Chen , M. Harrell, James D. Meindl, "Analytical Drain Current Compact Model in the Depletion Operation Region of Short- Channel MOSFET" IEEE Transaction on electronic device, Volume: 64, Issue: 1 Pages: 66 - 72 Year: 2017.
- [10] Zhang, L., Yu, Z. and He, X. (2009), "Design and Implementation of Ultralow Current-mode Amplifier for Biosensor Applications", *IEEE Transaction on Circuits and Systems II: Express Briefs*, Vol. 56, pp. 540–544, July 2009.
- [11] Sigroha, Naveen and Krishan, Bal (2015), "A High Bandwidth Low Power Supply CMOS Operational Amplifier", *IJSRD-International Journal for Scientific Research & Development*, Vol. 3, Issue 02, 2015 | ISSN (online): 2321-0613..

The Future of Wireless Everything

Ayush Gupta^{#1}, Deepak Kumar Singh^{*2}, Aviral Nigam^{#3}

[#]ECE Department, KIET group Of Institutions
 Ghaziabad, Uttar Pradesh, India

¹ayush.1631045@kiet.edu

²deepak.1631051@kiet.edu

³aviral.1631042@kiet.edu

II. NFC

Abstract— This paper would revolve around the wireless future of our planet. The rate at which technology is expanding it isn't a surprise on how people have started imagining things that only sounded like magic till now. Talking of technology, the world today can easily be termed as the "GADGET WORLD", given the astonishingly high rates at which gadgets are being developed, manufactured, and ultimately exploited by the end users. This paper would be consisting of some of the new technology supporting wireless world. The technologies like Sixth sense, IOT, LiFi, GiFi, NFC, wireless power transmission, EnOcean tech etc has been developed in the recent years. If these technologies would be supported the time is very soon where you would see the world without cables and power cords.

Keywords—Sixth Sense, LiFi, NFC, GADGET WORLD.

I. INTRODUCTION

Generally, in a communication system, information is transmitted from transmitter to receiver that are placed over a limited distance. With the help of Wireless Communication, the transmitter and receiver can be placed anywhere between few meters (like a T.V. Remote Control) to few thousand kilometres (Satellite Communication). We live in a World of communication and Wireless Communication, in particular is a key part of our lives. Some of the commonly used Wireless Communication Systems in our day – to – day life are: Mobile Phones, GPS Receivers, Remote Controls, Bluetooth Audio and Wi-Fi etc.

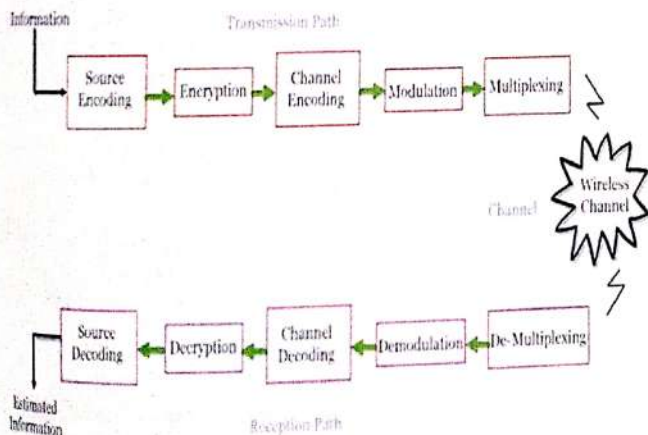

Fig.1 Block Diagram of Wireless Communication

A. Introduction

Near-field communication (NFC) is a set of communication protocols that enable two electronic devices, one of which is usually a portable device such as a smartphone, to establish communication by bringing them within 4 cm (1.6 in) of each other.

NFC devices are used in contactless payment systems, similar to those used in credit cards and electronic ticket smartcards and allow mobile payment to replace/supplement these systems. This is sometimes referred to as NFC/CTLS (Contactless) or CTLS NFC. NFC is used for social networking, for sharing contacts, photos, videos or files. NFC-enabled devices can act as electronic identity documents and keycards. NFC offers a low-speed connection with simple setup that can be used to bootstrap more capable wireless connections

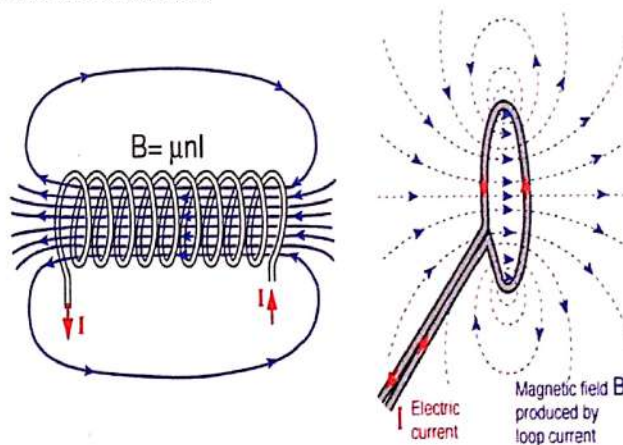

Fig.2 Working of NFC in Active Field.

NFC-enabled devices to exchange various pieces of information between each other. In this mode both devices switch between active when sending data and passive when receiving.

Read/write mode, on the other hand, is a one-way data.

B. Working

NFC works on the principle of sending information over radio waves. Near Field Communication is another standard for wireless data transitions.

The technology used in NFC is based on older RFID (Radio-frequency identification) ideas, which used electromagnetic induction in order to transmit information.

NFC technology does not command enough inductance to charge our smartphones.

A can send data at either 106, 212, or 424 kilobits per second. To determine what sort of information will be exchanged between devices, the NFC standard currently has three distinct modes of operation. Perhaps the most common use in smartphones is the peer-to-peer mode. This allows two transmission. The active device, possibly your smartphone, links up with another device in order to read information from it. NFC advert tags use this mode.

The final mode of operation is card emulation. The NFC device can function as a smart or contactless credit card and make payments or tap into public transport systems.

C. Application

NFC chips stocked inside credit cards for contactless payments are nothing new. But a slightly more recent - and admittedly more enticing - use case for NFC is with your smartphone, or even your smartwatch, as a way to digitize your entire wallet.

Samsung pay, which operates similarly, is available for Samsung phone users in the US, and expected to land in the UK soon.

Share internet passwords with your friends Most often than not, your Wi-Fi passwords will include numbers, alphabets, as well as symbols to make it more secure. However, when we want to share this password with your friends, it can be quite troublesome to spell it out verbally.

NFC WORK WITH THE BUTTONS

NFC is powered by the radio energy from the phone. The buttons decide what data (an ID) the NFC chip should communicate to the phone. As each strip can only be heard by a specific phone, they can communicate the same four IDs. The app then handles all the tricky stuff .iOS doesn't allow direct access to NFC (an intended limitation), hence only possible for Android, and likely also Windows Phone, at the moment.

III. ENOCEAN TECHNOLOGY

A. Introduction

EnOcean wireless technology uses a combination of energy harvesting and very low power wireless communications to enable virtually indefinite communications to be maintained without the need for recharging.

The EnOcean technology is used for wireless sensors, controllers and gateways.

One of the key issues with small machines is the need for ensuring that batteries are maintained charged. In traditional systems, either mains power was required, or batteries needed to be replaced, even if only infrequently. The use of EnOcean removes the need for power to be directly applied thereby reducing the cost of the system operation.

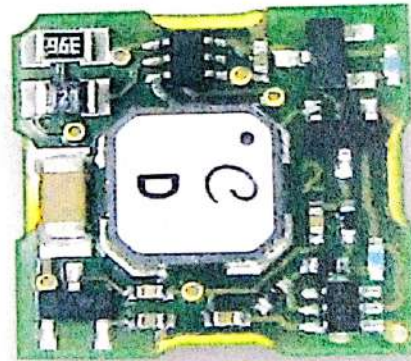

Fig.3 Ultra low power DC/DC converter for Thermoelectric

Energy Harvesting.to connect with other standards for an Internet of Things (IoT).

Flexible and maintenance-free sensor solutions Key EnOcean elements. The EnOcean standard is unique in that it encourages the use of energy harvesting to maintain the operation. Accordingly there are several different areas of interest within the overall EnOcean system.

Energy harvesting: One of the key elements of EnOcean is the ability to harvest local energy to power the remote devices. This overcomes key issues encountered by other systems. A number of energy harvesting systems are covered.

Radio Interface: The radio interface has been designed to provide optimum data transfer over the required distances using very low power levels. This makes the overall system sustainable, even with very small amounts of energy harvesting.

Data layers: The data needs to be transferred in an optimum way to ensure that the EnOcean system is able to provide robust communications.

B. Advantages

BUILDING AUTOMATION: Self-powered wireless switches, sensors and controls cut installation cost and time, and enable efficient use of energy.

SMART HOMES : EnOcean solutions increase comfort and security for smart homes.

Flexible and maintenance-free sensor solution.

Energy-efficient solution.

Cost and time savings in installation, maintenance and renovation.

PRODUCTS

- PTM 210: Push button multi-channel switch module.
- PTM 330: Transmitter module.
- STM 300: Energy harvesting wireless sensor module

C. Software Automation

EnOcean is newly supported by Fhem and ago control. Fhem and ago control are GPL licensed software suites for house automation. They are used to automate some common tasks in the household like switching lamps, shutters, heating, etc., and to log events like temperature, humidity, and power consumption. Both run as servers that are controlled via web front-end, telnet, command line, or TCP/IP directly.

D. Alliance

A group of companies including EnOcean, Texas Instruments, Omnio, Sylvania, Masco, and MK Electric formed the EnOcean Alliance in April 2008 as a non-profit, mutual benefit corporation. The EnOcean Alliance aims to internationalise this technology, and is dedicated to creating interoperability between the products of OEM partners, in order to bring about the existence of a broad range of interoperable wireless monitoring and controlling products for use in and around residential, commercial and industrial buildings.

An easy way to comply with the journal paper formatting requirements is to use this document as a template and simply type your text into it.

IV. LIFI

A. Introduction

LiFi is a wireless optical networking technology that uses light-emitting diodes (LEDs) for data transmission.

LiFi is designed to use LED light bulbs similar to those currently in use in many energy-conscious homes and offices. However, LiFi bulbs are outfitted with a chip that modulates the light imperceptibly for optical data transmission. LiFi data is transmitted by the LED bulbs and received by photoreceptors.

Li-Fi's early developmental models were capable of 156 megabits-per-second (Mbps). Some commercial kits enabling that speed have been released. In the lab, with stronger LEDs and different technology, researchers have enabled 10 gigabits-per-second (Gbps), which is faster than 802.11ad.

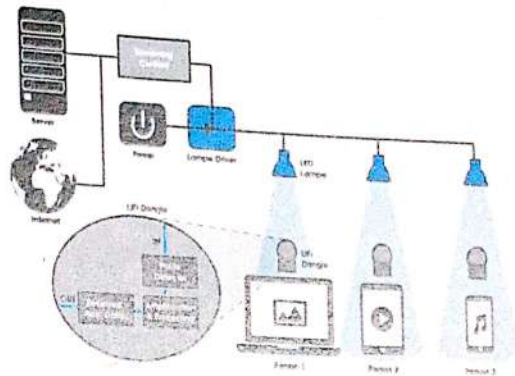
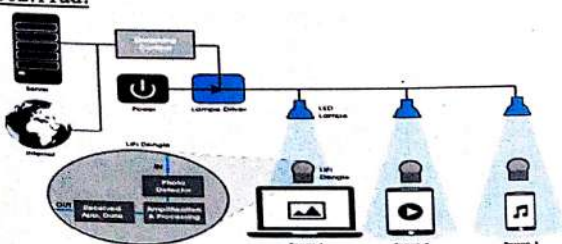

Fig.4 Block Diagram of LiFi

B. Working

The working of Li-Fi is very simple. There is a light emitter on one end i.e. an LED transmitter, and a photo detector (light sensor) on the other. The data input to the LED transmitter is encoded in to the light (technically referred to as Visible Light Communication) by varying the flickering rate at which the LEDs flicker 'on' and 'off' to generate different strings of 1s and 0s. The on off activity of the LED transmitter which seems to be invisible (The LED intensity is modulated so rapidly that human eye cannot notice, so the light of the LED appears constant to humans), enables data transmission in light form in accordance with the incoming binary codes: switching ON a LED is a logical '1', switching it OFF is a logical '0'. By varying the rate at which the LEDs flicker on and off, information can be encoded in the light to different combinations of 1s and 0s. In a typical setup, the transmitter (LED) is connected to the data network (Internet through the modem) and the receiver (photo detector/light sensor) on the receiving end receives the data as light signal and decodes the information, which is then displayed on the device connected to the receiver. The receiver (photo detector) registers a binary '1' when the transmitter (LED) is ON and a binary '0' when the transmitter (LED) is OFF. Thus flashing the LED numerous times or using an array of LEDs (perhaps of a few different colours) will eventually provide data rates in the range of hundreds of Mbps.

C. Advantages of LiFi

Efficiency: Li-Fi works on visible light technology. Since homes and offices already have LED bulbs for lighting purposes, the same source of light can be used to transmit data. Hence, it is very efficient in terms of costs as well as energy. Light must be on to transmit data, so when there is no need for light, it can be reduced to a point where it appears off to human eye, but is actually still on and working.

Availability: Wherever there is a light source, there can be Internet. Light bulbs are present everywhere – in homes,

offices, shops, malls and even planes, meaning that high-speed data transmission could be available everywhere. Security: One main advantage of Li-Fi is security. Since light cannot pass through opaque structures, Li-Fi Internet is available only to the users within a room and cannot be breached by users in other rooms or buildings.

D. Disadvantages of LiFi

Internet cannot be used without a light source. This could limit the locations and situations in which Li-Fi could be used. Because it uses visible light, and light cannot penetrate walls, the signal's range is limited by physical barriers.

V. SIXTH SENSE TECHNOLOGY

A. Introduction

Sixth Sense is a wearable gestural interface that enhances the physical world around us with digital information and lets us use natural hand gestures to interact with that information. Steve Mann is considered as the father of Sixth Sense technology who made a wearable computer in 1990. He implemented the Sixth Sense technology as the neck worn projector with a camera system. He was a media lab student at that time. Then his work was carried forward by Pranav Mistry, an Indian research assistant in MIT Media Lab. It is based on the concepts of augmented reality and has well implemented the perceptions of it. Sixth sense technology has integrated the real world objects with the digital world. The fabulous 6th sense technology is a blend of many exquisite technologies. The thing which makes it magnificent is the marvelous integration of all those technologies and presents it into a single portable and economical product. It associates technologies like hand gesture recognition, image capturing, processing, and manipulation, etc. It superimposes the digital world on the real world. The sixth sense technology uses different technologies like gesture recognition, image processing, etc. At present the commercial product isn't launched but the prototype is prepared.

B. Working

The sixth sense prototype is made using very common and easily available equipments like pocket projector, a mirror, mobile components, color markers and a camera. The projector projects visual images on a surface. This surface can be wall, table, book or even your hand. Thus, the entire world is available on your screen now. When user moves their hands to form different movements with colored markers on the finger tips, the camera captures these movements. Both the projector and the camera are connected to the mobile computing device in the user's pocket. Recognition is made using computer vision

technique. These markers act as visual tracking fiducials. The software program processes this video stream data and interprets the movements into gestures. The gestures are different from one another and are assigned some commands. These gestures can act as input to application which is projected by the projector. Since, the projector is aligned downwards for compactness; therefore images would be formed at the user's feet if mirror wasn't used. The mirror reflects the image formed by the projector to front. The entire hardware is fabricated in the form of a pendant.

C. Application

Sixth sense technology is developed to digitalized human behavior. In this system we have applied the technology to form a technology enabled Lecture Theatre. The system is developed to present a lecture in a different approach where everything is visible to students. It saves much time. Examples can be shown to students using images or video that is more approachable. Students can ask query from the system, and get replied instantly. The main goal of the system is to make the lecture delivery more efficient and smart, where the students can know what the future scope of concern subjects is and how it is related to their career. The visual implementation of programmatic solution for a project would be very helpful to them to understand the theoretical and practical concerns. In future the system could be extended by adding more new components in it.



Fig.5 Use of sixth sense

VI. IOT (INTERNET OF THINGS)

A. A. Introduction

The Internet of things (IoT) is the inter-networking of physical devices, vehicles (also referred to as "connected devices" and "smart devices"), buildings, and other items—embedded with electronics, software, sensors, actuators, and network connectivity that enable these objects to collect and exchange data.

The concept gained steam for its ability to connect the unconnected – physical-first objects previously incapable of generating, transmitting and receiving data unless augmented or manipulated. Embedding sensors, control systems, and processors into these objects enables horizontal communication across a multi-node, open network of physical-first objects. The term is also vaguely used to describe connected digital-first devices such as wearable gadgets that may be classified as Internet of Digital while offering the same functionality as its physical-first counterpart developed into a smart connected technology.

B. Working

An IoT system consists of sensors/devices which "talk" to the cloud through some kind of connectivity. Once the data gets to the cloud, software processes it and then might decide to perform an action, such as sending an alert or automatically adjusting the sensors/devices without the need for the user. But if the user input is needed or if the user simply wants to check in on the system, a user interface allows them to do so. Any adjustments or actions that the user makes are then sent in the opposite direction through the system: from the user interface, to the cloud, and back to the sensors/devices to make some kind of change.

C. Applications

Wearables, Smarthome, Smart City, Industrial, internetConnectedcar, Healthcare, Smart retail, IoT in Agriculture

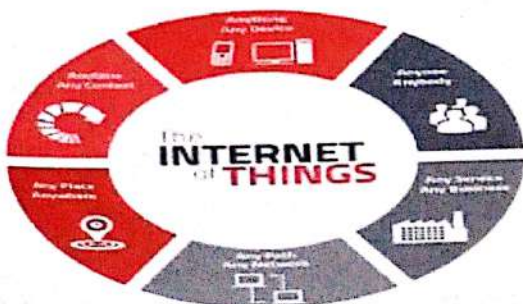

FIG.6 Applications of internet of things

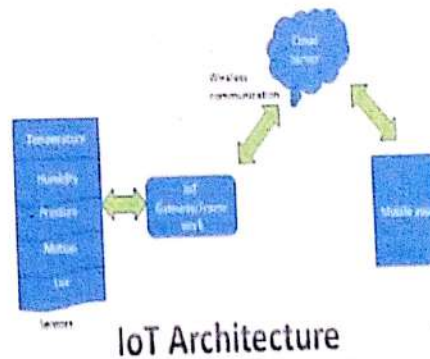
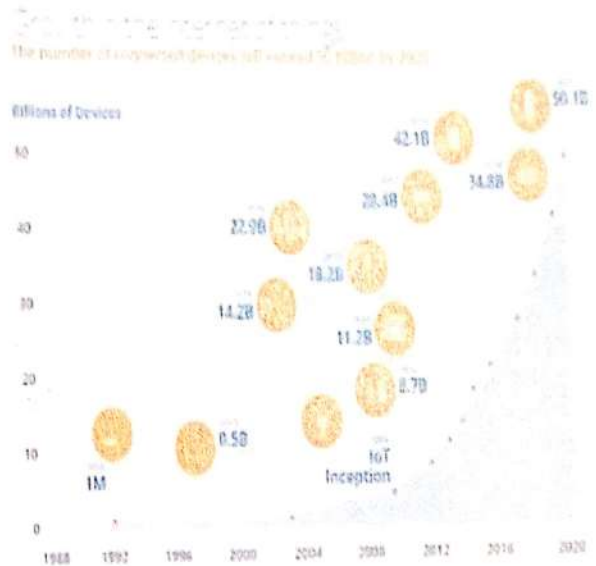

FIG8. IOT Architecture

VII. WIRELESS POWER TRANSMISSION-

A. A. Introduction

In this technology a space-based satellite is used to collect huge amounts of solar power, which is then converted into microwaves, transmitting electric power wirelessly to a pinpoint target using microwaves, to a Receiving rectenna (antenna) on the ground, and converted into DC energy for electrical use.

B. Rectenna

The concept and development of the rectenna arose in response to the need for a device that could be attached to a high altitude atmospheric platform and absorb and rectify microwave power from a microwave beam pointed at the vehicle.

C. Working

The receiving antenna (rectenna) converts the microwaves into DC power by taking the microwave in through the regular receiving antenna, then passing the signal through a Rectifying Diode, which then usually passes through a Low Pass Filter, which then ultimately passes into a DC to DC step up / step down “buck converter” — to scale up the power or scale down the power for using regular household electric powered items. Whatever signal the antenna picks up is originally in “AC” inside the antenna, thus a “rectifying diode” is needed to obtain useable steady voltage... rectifying the radio wave into DC voltage.

VIII. CONCLUSION

As What can be concluded from reviews of the current definition of ‘wireless’ and the ongoing developments, it seems there’s quite some time for the wireless technology to surface and compete with the already available options. The wireless future isn’t immediate and the transition will take its own pace, taking baby steps, one at a time.

IX. REFERENCES

- [1] Wireless World: Social and Interactional Aspects of the Mobile Age. By Nicola Green, Barry Brown.
- [2] Wireless networking technology, Book by Steve Rackley
- [3] <https://link.springer.com/article/10.1023/A:1013782614004>
- [4] <https://www.postscapes.com/internet-of-things-technologies/>
- [5] <https://www.thetrustcompass.com/top-trends-in-wireless-technology/>

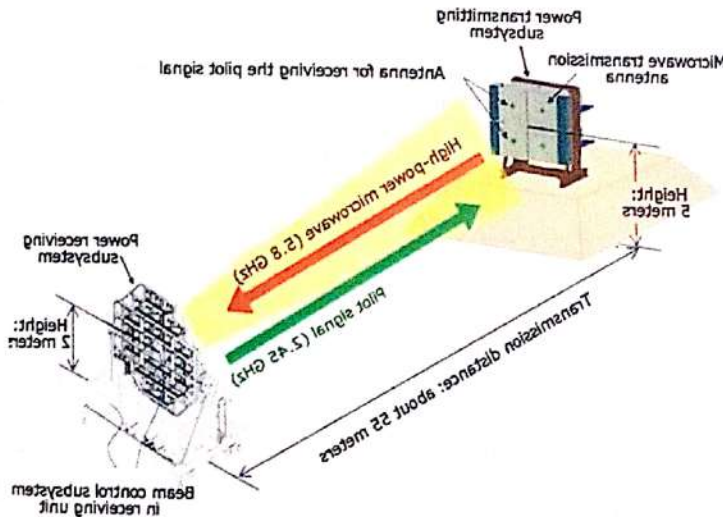

Fig 9. Wireless Power Transmission

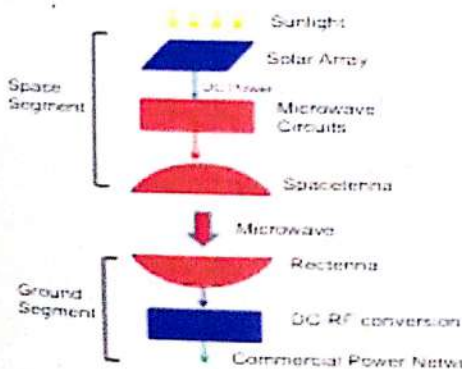

Fig 10. Flow chart of Energy Conversion System